



1000 MIGLIA 2024
Brescia, from 09th to 15th June 2024

SPECIAL RACE REGULATIONS
(SRR)

This draft of the Special Race Regulations together with its attached: Times and Distances Table – Route maps – Signage of controls - Table of coefficients – Table of scores for Time Trials – Table of scores for Average Trials, was sent to ACI SPORT for approval the 7th November 2023 and published on the organizer website on the 7th November 2023

ORGANISATION: 1000 Miglia S.r.l.

PREVIOUS MILLE MIGLIA WINNERS

Year	Drivers	Car	Cl.	Cm ³	CV	Brescia-Rome	Total time	Avg.
1927	Minoja – Morandi	OM 665 SPORT	6	1.999	80	7:25'00"	21:04'48"	77,238
1928	Campari – Ramponi	ALFA ROMEO 6C 1500 SS	6	1.487	84	6:46'00"	19:14'05"	84,128
1929	Campari – Ramponi	ALFA ROMEO 6C 1750 SS	6	1.752	90	6:26'00"	18:04'23"	89,688
1930	Nuvolari – Guidotti	ALFA ROMEO 6C 1750 GS	6	1.752	102	6:02'00"	16:18'59"	100,45
1931	Caracciola - Sebastian	MERCEDES -BENZ SSKL	6	7.065	280	6:03'25"	16:10'10"	101,15
1932	Borzacchini - Bignami	ALFA ROMEO 8C 2300 SPIDER	8	2.336	150	5:40'00"	14:55'19"	109,88
1933	Nuvolari - Compagnoni	ALFA ROMEO 8C 2300 SPIDER	8	2.336	160	5:33'26"	15:11'50"	108,58
1934	Varzi – Bignami	ALFA ROMEO 8C 2600 MONZA	8	2.556	180	5:51'34"	14:08'05"	114,31
1935	Pintacuda - Della Stufa	ALFA ROMEO TIPO B "P3"	8	2.905	240	5:28'09"	14:04'47"	114,75
1936	Brivio – Ongaro	ALFA ROMEO 8C 2900 A	8	2.905	230	5:25'50"	13:07'51"	121,62
1937	Pintacuda - Mambelli	ALFA ROMEO 8C 2900 A	8	2.905	255	5:27'55"	14:17'32"	114,75
1938	Biondetti - Stefani	ALFA ROMEO 8C 2900 B MM	8	2.905	250	5:34'56"	11:58'29"	135,39
1940	von Hanstein - Baumer	BMW 328 BERLINETTA	6	1.971	120		8:54:46"	166,72
1947	Romano - Biondetti	ALFA ROMEO 8C 2900 B BERLINETTA	8	2.905	180	6:35'00"	16:16'39"	112,24
1948	Biondetti - Navona	FERRARI 166 S COUPE'	12	1.995	120	6:02'00"	15:05'44"	121,23
1949	Biondetti - Salani	FERRARI 166 MM SPIDER	12	1.995	140	5:13'43"	12:07'05"	131,46
1950	Marzotto G. - Crosara	FERRARI 195 S BERLINETTA	12	2.341	170	6:55'45"	13:39'20"	123,21
1951	Villoresi - Cassani	FERRARI 340 AMERICA BERLINETTA	12	4.101	230	7:18'55"	12:50'18"	121,82
1952	Bracco – Rolfo	FERRARI 250 S BERLINETTA	12	2.953	230	6:57'53"	12:09'45"	128,59
1953	Marzotto - Crosara	FERRARI 340 MM SPIDER	12	4.101	280	6:19'20"	10:37'19"	142,35
1954	Ascari A.	LANCIA D24 SPIDER	6	3.284	245	6:02'00"	11:26'10"	139,65
1955	Moss - Jenkinson	MERCEDES-BENZ 300 SLR	8	2.979	310	5:03'02"	10:07'48"	157,65
1956	Castellotti	FERRARI 290 MM	12	3.490	320	5:41'30"	11:37'10"	137,44
1957	Taruffi	FERRARI 315 S	12	3.783	360	5:08'38"	10:27'47"	152,63
1958	Taramazzo	FERRARI 250 GT	12	2.953	250		0:55'02"	
1959	Abate - Balzarini	FERRARI 250 GT	12	2.953	260		2:06'16"	
1961	Andersson - Lohmander	FERRARI 250 GT	12	2.953	280		3:32'53"	

INDEX

Articles:

1.	DEFINITIONS.....	4
2.	ORGANISATION	6
3.	PROGRAMME	7
4.	RACE.....	10
5.	ROUTE	10
6.	COMPETITORS, DRIVERS AND CARS ALLOWED	10
7.	RACE NUMBER AND STARTING ORDER	14
8.	ENTRIES.....	14
9.	GENERAL OBLIGATIONS.....	20
10.	RUNNING OF THE RACE	23
11.	MAXIMUM LATENESS.....	25
12.	PENALTIES AND DISCIPLINARY MEASURES.....	25
13.	CLASSIFICATION-PROTESTS AND APPEALS	26
14.	PRIZES	26
15.	GENERAL RULES	27
16.	INSURANCE	28
17.	APPENDIXES	
	01. Facsimile of the Medical Certificate for non-competitive sports activity	31
	02. Positioning of the Race numbers on the cars.....	32
	03. Itinerary, Times and Distance Table (The TDT will be distributed together with the Road book).....	33
	04. Maps.....	33
	(The maps may be subject to modification and will be distributed together with the Road book)	
	05. Signage of Controls.....	34
	06. Table of Coefficients.....	36
	07. Table of scores for Time Trials (PC/TT)	56
	08. Table of scores for Average Trials (PM/AT).....	58

1. DEFINITIONS

Unless otherwise defined in the body of these SRR or in the General Terms and Conditions, the following terms shall have the following meanings:

- 1.1 ASN:** means the National Sporting Association/Federation recognised by the International Automobile Federation in each country as the only sporting power qualified to apply the code of ethics adopted by the same and to regulate motor sports in all the territories under its jurisdiction.
- 1.2 Admitted Drivers:** means the Crew members admitted and verified to drive the car entered by the Competitor.
- 1.3 Chairman of the Stewards:** these are the officials indicated in Art. 2.4 of these SRR.
- 1.4 Clerk of the Course:** means the official as per art. 2.4 of these SRR.
- 1.5 Co-Driver:** means the Crew member assisting the driver.
- 1.6 Coefficient Tables (TDC):** means the correction coefficients of the cars that can be entered in the Event applied to compensate and equalise the technical and performance characteristics of the same, as per the tables attached to the SRR.
- 1.7 Competitor(s):** means the natural or legal person holding a Sports Licence suitable to enter a car and its drivers for the Event.
- 1.8 CO/TC:** means the time control(s) that regulates/regulate the timing of the race.
- 1.9 CPI:** means the personal identification mark suitable to uniquely and incontrovertibly identify a Driver.
- 1.10 Crew:** means the crew appointed by the Competitor for each entered and/or admitted car composed of a maximum of 2 (two) Drivers.
- 1.11 CSN:** means the national sports code adopted by ACI Sport.
- 1.12 CT/PC:** means the passage controls.
- 1.13 Driver:** means the natural person who takes part in the race with the role of driver and/or co-driver of an entered car. The driver(s) is/are indicated by the Competitor and must be in possession of the requirements of art. 6 of these SRR.
- 1.14 Driver:** means the Crew member driving the car.
- 1.15 FIA HERITAGE CERTIFICATE:** means the certificate issued by the Federation Internationale de l'Automobile.
- 1.16 FICHE ACI SPORT:** means the national technical document issued by Automobile Club Italia.
- 1.17 FIVA INTERNATIONAL IDENTITY CARD:** means the international document issued by the Fédération Internationale des Véhicules Anciens.
- 1.18 General Terms and Conditions:** these are the general terms and conditions containing the terms and conditions of entry of competitors and forming an integral part of these SRR for anything not expressly derogated from or supplemented by the same.
- 1.19 GPS TRACKER:** means the electronic equipment made available by the Organiser and installed on the vehicle.
- 1.20 Guest Car:** means a car entered with a specific application for entry and admitted to a special classification.
- 1.21 HTP/FIA:** means the *Historical Technical Passport* of the car issued by the *Federation Internationale de l'Automobile*.
- 1.22 Leg:** means the leg of the race scheduled in the Programme.

- 1.23 OM brand:** means the brand of the car(s) produced by Officine Meccaniche (formerly Miani e Silvestri & C - A. Grondona Comi & C. of Milan) founded in 1899 and closed down in 1975.
- 1.24 Operating and Selection Committee:** means the committee composed of the members referred to in art. 2.3 of these SRR, appointed by the Organiser, with the task of proposing the admission to and/or exclusion of the cars from the Event.
- 1.25 Organiser:** means 1000 Miglia S.r.l. with registered office in Brescia, Via Enzo Ferrari 4/6, holder of ACI Sport licence n. 356540, Tax Code and VAT no. 03440020984, registered with the Brescia Companies' Register under n. 534270.
- 1.26 Paddock:** means the area set up by the Organiser to carry out the administrative checks and scrutineering for the race.
- 1.27 PC/TT:** means the time trials.
- 1.28 PM/AT:** means the average trials.
- 1.29 Programme:** means the race programme referred to in art. 3 of these SRR.
- 1.30 Race:** means the car race called "1000 MIGLIA 2024"
- 1.31 Race Officials:** means the race officials referred to in Article 2.4 of these SRR
- 1.32 Registered Trademarks:** means the following trademarks: "MILLE MIGLIA", "1000 Miglia" both verbal and figurative.
- 1.33 RNS:** means the National Sporting Regulations adopted by ACI Sport and its sector regulations, as applicable.
- 1.34 Road Book:** means the document prepared by the Organiser indicating the route of the Race.
- 1.35 Special List:** means the list of no more than 30 (thirty) cars, selected by the Organiser, which are of high historical and/or sporting interest and which were not entered into the 1000 Miglia 1927-1957 or whose year of construction is prior to 1927.
- 1.36 Sponsor:** means sponsors who have a sponsorship contract with the Organiser.
- 1.37 Sponsor Team:** means the team of cars indicated by the sponsor in its team in accordance with the sponsorship contract.
- 1.38 SRR:** means these Special Race Regulations.
- 1.39 TDT:** means the itinerary, times and distance table attached to the SRR, the final version of which is included in the Road Book or in the Information Bulletins.
- 1.40 Technical Support Convoy:** this refers to the pathfinder, "pace car" and "technical car" as well as other vehicles defined and appointed by the Organiser and their crews.
- 1.41 Time Card:** means the document showing the transit times recorded at the CO/TCs.
- 1.42 Website:** means the website <https://1000miglia.it/>.
- 1.43 Waiting List:** this is the waiting list prepared by the Organiser for the competitors who have applied for entry but have not been accepted by the date of publication of the list of Competitors and cars admitted.

All the times stated in these SR are understood as referring to the Time Zone in use in Italy, namely "Greenwich Mean Time + 1 hour" conventionally UTC (GPS) signal | Italy: GMT+1

Value Added Tax (VAT) will be applied on all amounts stated in these SR at a rate of 22% (updated to 20.10.2023). Any variation on this percentage will be notified in the Bulletin and will be enforced in compliance with the laws issued by Italy.

To all legal effects, the Italian version of these SRR will be binding. The English translation of the same is understood as being solely for information purposes.

2. ORGANISATION

2.1. This event will be run in compliance with the RNS and with other provisions of the ACI Sport, which are understood to regulate whatever is not indicated in the following articles.

2.2. The Organiser states that the race will have all the necessary administrative authorisations and the required insurance coverage.

2.3. The Operational and Participant Selection Committee is composed of:

Chairman: Mr.
 Vice Chairman: Mr.
 Secretary: Mr.
 Members: Mr.
 Members: Mr.
 Members: Mr.
 Head office: 1000 MIGLIA s.r.l. - Via Enzo Ferrari, 4/6 - 25134 - Brescia

2.4. OFFICIALS

Sports commissioners:
 - Chairman of Stewards Mr. t.b.a. (ASN Sport Delegate) licence
 - Steward Mr. t.b.a. licence
 - Steward Mr. t.b.a. licence
 - Stewards' secretary Mr. t.b.a. licence
 Clerk of the course: Mr. Lucio DE MORI licence 20623
 Deputy Clerk of the course: Mr. t.b.a. licence
 Event Secretary: Mr. t.b.a. licence
 Safety Manager: Mr. t.b.a. licence
 Chief Medical Officer: Dr. t.b.a. licence
 Competitor Relations Officers: The list will be published by a Bulletin
 Judges of fact: The list will be published by a Bulletin
 Sporting Operations Inspectors: The list will be published by a Bulletin
 Scrutineers: Mr. t.b.a. (ACI Sport delegate) licence
 Scrutineers and Scrutineer Assistant: The list will be published by a Bulletin
 Marshals: of the Automobile Club Brescia and of the Automobile Clubs of other affected Provinces
 Time keeping Service: Federazione Italiana Cronometristi (F.I.C.R.)
 Head of Timing Service: Mr. t.b.a. licence
 Results: Mr. t.b.a. licence
 Press Officer: Mr. t.b.a. licence

3. PROGRAMME

3.1 Programme before the race week

Tuesday 7 November 2023

Date of publication of SR

Website

Opening date for entries

Race Secretary

Tuesday 16 January 2024 at 16:00

Closing Date for entries

Race Secretary

Wednesday 24 January 2024 at 16:00

Closing Date for entries reserved for cars indicated by Sponsors, according to sponsorship contracts

Race Secretary

Deadline for communication of crews belonging to a "Sponsor Team"

Race Secretary

Monday 26 February 2024 at 16:00

Deadline for communication of crews belonging to a "Sponsor Team"

Race Secretary

by Friday 12 April 2024

Communication to entrants of their acceptance, acceptance of the cars And relative coefficients assigned

Race Secretary

Publication of list of Competitors and cars accepted

Website

Thursday 16 May 2024 at 16:00

Final date for communicating the free of charge variation of the data of the drivers not indicated during the entry phase

Race Secretary

Deadline for the free of charge request of change an entered car

Race Secretary

Deadline for sending of graphics for a Sponsor Team sticker

Race Secretary

Deadline for sending the documents required to carry out pre-checks

Race Secretary

Monday 3 June 2024

Deadline for the refund of deposit payment from competitors who have not been accepted and who were not on the waiting list

Race Secretary

Closing Date for the waiting list

Race Secretary

Monday 3 June 2024

Briefing of the Organisers and the Clerk of the course

Sent to each entrant

Tuesday 4 June 2024

Publication of individual verification schedules

Website - ONB

By Saturday 8 June 2024 at 12:00 am

Publication of individual starting order and times of the 4 Legs

Website – ONB

3.2 Programme for the race Week

The times shown on the programme for all activities which precede the start of the race will be confirmed by a board showing the official time of the event, placed in the inspection area by the Timekeeping service.

All crew members who have not reported within the times stated in these SRR will be understood as having withdrawn and will not be admitted to the race; no exceptions will be made.

Sunday 9 June 2024

10:00 - 19:00 Administrative checks, scrutineering and Road Book distribution (according to individual convocation times communicated)

Brescia, Paddock Expo

Monday 10 June 2024

10:00 - 19:00 Administrative checks, scrutineering and Road Book distribution (according to individual times communicated)

Brescia, Paddock Expo

10:00 - 20:00 Sealing and Presentation ceremony of the cars (according to individual times communicated at the Scrutineering)

Brescia, Piazza Vittoria

Up until 20:00	Exhibition of the sealed cars	City centre square
Tuesday 11 June 2024		
07:30 - 08:30	Administrative checks, scrutineering and Road Book distribution (according to individual convocation times communicated)	Brescia, Paddock Expo
07:30 - 08:30	Entry of Crews on the "Waiting List"	Brescia, Paddock Expo
09:00 - 10:00	Administrative checks and scrutineering, for Crews on the "Waiting List"	Brescia, Paddock Expo
08:30 - 11:30	Sealing of the scrutineered cars (according to individual times communicated at the Scrutineering)	Brescia, Piazza Vittoria
Up until 12:00	Exhibition of the sealed cars	City centre square
12:00	Publication of list of competitors and accepted cars	Website - ONB
from 11:30	Lining up for start of Leg 1	Brescia, Viale Venezia
12:00	Departure of first car – Leg 1	Brescia, Viale Venezia
20:30	Arrival of first car – Leg 1	Turin - TBD
Wednesday 12 June 2024		
07:15	Publication of partial classification of Leg 1	Website - ONB
from 07:15	Lining up for start of Leg 2 (minimum 30' before the individual starting time)	Turin - TBD
07:45	Departure of first car – Leg 2	Turin - TBD
19:45	Arrival of first car – Leg 2	Viareggio - TBD
Thursday 13 June 2024		
05:45	Publication of partial classification of Leg 2	Website - ONB
from 05:45	Lining up for start of Leg 3 (minimum 30' before the individual starting time)	Viareggio - TBD
06:15	Departure of first car - Leg 3	Viareggio - TBD
20:30	Arrival of first car - Leg 3	Rome, Via Veneto
Friday 14 June 2024		
05:45	Publication of partial classification of Leg 3	Website - ONB
from 05:45	Lining up for start of Leg 4 (minimum 30' before the individual starting time)	Rome, Villa Borghese
06:15	Departure of first car - Leg 4	Rome, Villa Borghese
21:35	Arrival of first car - Leg 4	Bologna - TBD
Saturday 15 June 2024		
05:30	Publication of partial classification of Leg 4	Website – ONB
from 05:30	Lining up for start of Leg 5 (minimum 30' before the individual start time)	
06:00	Departure of first car - Leg 5	
14:00	Arrival of first car - Leg 5 and passage on the ramp	
from 14:30	Mandatory Passage on the ramp	Brescia, Viale Venezia
18:00	Publication of final classification	Website – ONB
19:30	Prize giving ceremony	Brescia, TBA

Race Headquarters, Race Secretary and Paddock

Brixia Expo - Fiera di Brescia, Via Caprera 5 – 25125 - Brescia

Leg Secretaries

Turin - TBD

from 20:00 of Tuesday 11th to 01:00 of Wednesday 12th June 2024

Viareggio - TBD
from 18:00 to 00:00 of Wednesday 12th June 2024

Rome – TBD
from 18:00 to 00:00 of Thursday 13th June 2024

Bologna – TBD
from 18:00 to 00:00 of Friday 14th June 2024

Official Notice Board (ONB)

- **Website**

Brescia (race Headquarters), Leg Secretaries, Website and App Sportity

www.1000miglia.it

- **App Sportity**

password: 1000Miglia2024

Synchronization of the Organisation's time-keeping systems: **UTC (GPS) signal** | Italia: GMT+1

4. RACE

The Organiser 1000 MIGLIA S.r.l. announce and organise, as from Sunday 9th June to Saturday 15th June 2024 a Classic Regularity Race for Historical Cars, Grande Evento, to be known as:

1000 MIGLIA 2024

5. ROUTE

The race route will have an overall length of Km 2.120 and will be described in the Itinerary Table (TDT) attached to these SRR, and of which it is an integral part, and in the Road Book. The TDT will also show the methods of carrying out the timed Legs for classification.

There will be 21 Time Controls (CO/TC), 145 Time Trials (PC/TT), 11 Average Trials (PM/AT) with a total of 23 readings and 29 Passage Controls (CT/PC).

The start and finish of the race are scheduled at the places and times indicated in the race Programme.

The race will take place on roads open to traffic, barring any limitations set by the competent Administration Authorities, with average speeds not exceeding 50 Km/h.

Any route changes due to road works, or temporary obstructions, will be notified with Bulletins directly on site, if possible, by the Police or by persons appointed by the organisation.

6. COMPETITORS, DRIVERS AND CARS ALLOWED

6.1 COMPETITORS AND DRIVERS ALLOWED

6.1.1 Competitors, and crew members must hold a valid ACI Sport Competitor/Driver's Licence or a valid regularity licence (for Italian competitors/Drivers) or a valid Co-driver or Competitor/Driver's licence, issued by their ASN (for foreign competitors/drivers of International or National - with authorisation to compete in the event - level) valid in Italy.

6.1.2 At least one of the two crew members must be in possession of a valid driving licence during all the legs of the race. Crew members without an Italian driving licence, or in any case valid in Italy, must also present, if necessary, an international driving licence, valid in Italy.

6.1.3 For each vehicle, a competitor may enter a crew, comprising of maximum 2 persons, who must be on board the vehicle during all phases of the race.

6.1.4 A competitor who is a physical entity, entering a vehicle for the race must always be on board the vehicle throughout the race. In the case of a Competitor being a legal person, he/she may enter more than one car and appoint a Crew for each one, but it is expressly forbidden to exchange Crews between the entered cars.

6.1.5 During all the phases of the race the vehicle may be driven only by crew members who have been verified as drivers and accepted with that specific vehicle.

6.1.6 Crew members below the age of 14 (i.e. those who have not yet turned 14 at the date of the end of the checks) and older than 85 years of age (i.e. those who will not have reached 86 years of age on 15.06.2024).

6.1.7 Passengers will not be allowed, that is, crew-members who have not been verified and who are not in possession of the requirements of Articles 6.1.1, 6.1.2 and 6.1.6 of these SRR.

6.1.8 The substitution of a competitor after the close of entries, is not permitted. Crew members may be replaced:

- a. with the authorisation of the Organiser, up to the start of administrative checks;
- b. with the authorisation of the Stewards, from the start of checks until publication of list of admitted competitors and crews and of the accepted race cars.

The substitution of two members of the crew is subject to the approval of the Organiser, in accordance with the ASN of the organiser.

6.1.9 Until 4:00 p.m. on Thursday 16th May 2024, the first replacement of both crew members or the inclusion of names not previously communicated are free of charge. From 16:01 p.m. on Thursday 16th May 2024 each replacement or insertion of a crew member will have to be paid for an amount of € 366,00 (equal to € 300,00 + VAT), as administration fees.

If payment is not made, the request for replacement will not be considered valid.

It will not be possible to replace both crew members if the car has already been replaced. This provision does not apply to entries for "Sponsor Team" cars/crew members.

6.2 DOCUMENTATION REQUIRED IN ORDER TO OBTAIN A SPORTS LICENCE

The maximum age for obtaining the regularity licence, whether daily for foreigners or annual for Italians, is 85 years for both sexes. Below is the list of the documentation necessary for obtaining the prescribed licence:

a) Drivers of Italian nationality UNDER 85 at the date of the closure of the race

In order to issue/renew the licence, the following documents are required:

- medical certificate for non-competitive sports activities (Facsimile in Appendix 1 to these SR) obtained in Italy as per current regulations;
- driving licence (only for drivers);
- ACI membership card (for those not in good standing with the association, it will be possible to renew/issue this on-site by communicating the data of the car used every day, or the licence plate number of the historic car entered in the race, depending on the type of ACI Service required).

b) Co-drivers (not permitted to drive the car) of Italian nationality UNDER 85 at the date of the end of the race

In order to issue/renew the licence, the following documents are required:

- medical certificate for non-competitive sports activities (Facsimile in Appendix 1 to these SR) obtained in Italy as per current regulations;
- ACI membership card (for those not in good standing with the association, it will be possible to renew/issue this on-site by communicating the data of the car used every day, or the licence plate number of the historic car entered in the race, depending on the type of ACI Service required).

c) Drivers not of Italian nationality UNDER 85 at the date of the end of the race

In order to issue/renew the licence, the following documents are required:

- medical certificate for non-competitive sports activities (Facsimile in Appendix 1 to these SR) obtained in Italy as per current regulations; alternatively, a medical certificate of good health issued abroad, written in English, signed and stamped by a doctor.
- self-certification stating you do not hold other valid licences issued by other ASN and to not having incurred disciplinary sanctions;
- national and international driving licence

d) Co-drivers (not permitted to drive the car) not of Italian nationality UNDER 85 at the date of the end of the race

In order to issue/renew the licence, the following documents are required:

- medical certificate for non-competitive sports activities (Facsimile in Appendix 2 to these SR) obtained in Italy as per current regulations; alternatively, a medical certificate of good health issued abroad, written in English, signed and stamped by a doctor.
- self-certification to not possessing other valid licences issued by other ASN and to not having incurred disciplinary sanctions;

6.3 SPONSOR

The Sponsors of 1000 Miglia 2024 who are entitled, by contract, will be able to:

- a) Enter cars until Wednesday 24th January 2024 (Article 8.3.2 of these SR)
- b) convey the names of the crews free of charge by and not later than 26th May 2023. After this date, the art. 6.1.8 and 6.1.9 of the present SR will be considered valid.
- c) designate, within the vehicles forming part of their quota, one or more cars named "Guest Car" (Article 6.4. of these SR).

6.4 SPONSOR TEAM

The cars indicated by the sponsors in their quota, as per the sponsorship contract, will form the "Sponsor Team" which will benefit from the following conditions:

- a) the use of an additional advertising space (adhesive) on the sides of the race car (Article 15.3 in these SR) for each car that is part of the sponsor team;
- b) the possibility of including one or more race cars registered for the event in a "Sponsor Team" (Article 7.3 in these SR) in the starting order.

6.5 GUEST CAR

Sponsors who are entitled by contract (Article 6.3 of these SR) have the possibility to designate one or more cars called "Guest Car" within the vehicles forming part of their quota.

Competitors who opt for Platinum entry (Article 8.10.3 of this RPG) will use the "Guest Car" option for the vehicle registered by them without any possibility of waiver.

- 6.5.1 The competitor entering a "Guest Car" can enter more than one driver for the car, up to a maximum of 6 drivers.
- 6.5.2 It is obligatory for the competitors and at least one of the crew members of a "Guest Car" to submit to the sports checks in Brescia according to the methods described in Article 9.1 below.
- 6.5.3 Also crew members who have completed the administrative checks at the Leg Secretariats (Turin, Viareggio, Rome and Bologna) may drive the car after having passed the prescribed checks. Competitors being physical persons who enter a "Guest Car" must be on board the car.
- 6.5.4 Should entrants registered with the Guest Car formula choose to carry out scrutineering at the Leg Secretariats, they must communicate within 15 days from the start of the race for which drivers this solution is required and at the end of which leg. For each identified driver, all documents necessary to pass the Sporting Checks (licence, medical examination, driving licence, international licence if any) must be sent in advance to the organiser by e-mail through his account within the abovementioned deadline. Each leg secretariat will carry out the scrutineering from 21.00 to 22.00 on each single day of activity.
- 6.5.5 Physical person competitors registering a "Guest Car" must then physically be aboard the said car.
- 6.5.6 Should a "Guest Car" be registered by a Legal Entity Competitor, the drivers who are registered and checked will be free to alternate their positions on board the car.
- 6.5.7 Competitors and drivers participating at the race on board a "Guest Car" must comply fully with these SR.
- 6.5.8 Vehicles with Platinum entry or designated as part of Sponsorship contracts such as "Guest Car" will be classified exclusively in a dedicated ranking.

6.6 ACCEPTED CARS

- 6.6.1 Race cars classified in periods C, D, E and those models registered for the 1000 Miglia Speed race (1927 - 1957), will be accepted.

Accepted cars will be divided into the following 3 groupings:

- a) 1st Grouping race cars belonging to Period C (vehicles built from 1927 to 1930)
- b) 2nd Grouping race cars belonging to Period D (vehicles built from 1931 to 1946)
- c) 3rd Grouping race cars belonging to Period E (vehicles built from 1947 to 1957)

- 6.6.2 Cars built after 1957 will not be accepted.
- 6.6.3 Cars built before 1927, limited to those models which were registered in the 1000 Miglia speed race(1927 > 1957), may be accepted.
- 6.6.4 Up to 405 race cars will be accepted, of which up to n. 30 belonging to the Special List (see Article 6.6.6 of these SR) as well as 15 cars admitted with a cultural and educational purpose.
- 6.6.5 The entered car will be evaluated based on the documents inserted during the entry phase. The Selection Committee has the authority to exclude from the race an accepted car should it become aware of documents or facts that lead to the exclusion of the vehicle.
- 6.6.6 **Race cars, selected by the Organiser, that are of great historical and/or sports interest, and that, in respect of periods indicated above, were not registered in the 1000 Miglia speed race (1927>1957), may be accepted in the "Special List". The Operations Committee will establish which cars to accept into the "Special List", with independent and final decisions.**
- 6.6.7 To be entered into the Race, all the cars must have the 1000 Miglia Registro Certificate or the temporary entry number issued by the Registro itself upon completion of the entry procedure. In all cases, regardless of the person who submits the application to enter a car for the 1000 Miglia, the vehicle must be in good standing with the payment of the annual membership fee of the Registro 1000 Miglia, otherwise the system will not allow the car to be entered for the race. This obligation does not exist for cars admitted with a cultural and educational purpose.
- 6.6.8 To be eligible for selection, the entered cars must have obtained the Provisional or Final Certificate of the

Registro 1000 Miglia before the publication of the list of accepted cars. This obligation does not exist for cars admitted with a cultural and educational purpose.

- 6.6.9** In addition to this document, the valid FIVA International Identity Card and/or the FIA Heritage Certificate and/or Fiche ACI Sport and/or the FIA HTP are required.
- 6.6.10** Race cars will be registered with Make and Model and year of manufacture referred exclusively to the mentioned documents.
- 6.6.11** The cars entered must comply with the periodic revision of the vehicles if required and in accordance with the provisions of the laws of the country of registration. If the country of registration does not provide for the periodic revision of the cars, the competitor must produce a self-declaration in which he must declare the lack of need for revision according to the laws of the country of registration and consequently, he will declare to be able to circulate in his own country of origin having undergone all the technical checks to demonstrate the perfect efficiency of the car and all its devices. In the absence of this document the crew will not be able to pass the administrative checks.
- 6.6.12** The cars must also meet all the requirements to circulate within Italian territory.

6.7 REPLACEMENT OF A RACE CAR

6.7.1 CONDITIONS FOR SUBSTITUTION

Until 16:00 on Thursday 16th May 2024, the replacement of a car accepted or inserted in the waiting list is allowed. A car accepted or included in the Waiting List may be replaced, subject to payment according to the provisions of article 6.5.2 below and subject to the approval of the Organiser, only with another car that meets all the requirements of these SRR according to the TDC (Coefficient Tables) 1000 Miglia 1927-1957.

In case of non-acceptance of the entry, in order to obtain the acceptance, the Competitor will not be able to request the replacement of the car. This provision does not apply to entries for Sponsor Team cars.

It will not be possible to replace the car if both crew members have already been replaced. This provision does not apply to entries for Sponsor Team cars.

6.7.2 REQUIREMENTS FOR REQUESTING THE SUBSTITUTION OF A RACE CAR

In order to request the replacement of a car, the Competitor must send the appropriate form made available to the Organiser on the Website by e-mail to participants@1000miglia.it with a request for acceptance by the receiver and followed by confirmation of receipt by the receiver attaching the documentation in the form. Competitors provided with certified e-mail (PEC) must send the abovementioned notice to the PEC address: 1000miglia@legalmail.it.

The substitution of the race car requires the mandatory payment of € 2.440,00 (i.e. € 2000,00 + VAT 22%) for administrative fees, payable to the IBAN number stated on the car substitution form. In the absence of such payment, the request for substitution will not be taken into consideration. The Organiser will contact the competitor within 10 days from receipt of the request for substitution, accompanied by the bank transfer.

6.8 COEFFICIENTS ASSIGNED TO RACE CARS

In order to compensate and equate technical and performance characteristics of the race cars in the race, correction coefficients will be assigned based on the design and period of construction of the vehicle. The coefficients assigned are described in the table attached to these SRR.

The coefficient assigned to each accepted race car will be published by Friday 12th April 2024; each competitor may submit other documentary integrations aimed at the definitive assigning of a coefficient, within 15 days from the date of publication. No exceptions will be allowed to the terms stated above. All race cars accepted in the "Special List" will be assigned a coefficient of 1.00.

- 6.8.1** The use of a temporary number plate is always prohibited, under penalty of immediate exclusion.
- 6.8.2** The following are always prohibited, subject to a penalty which may include exclusion, at the Stewards discretion:
- a)** the installation and use of any protrusion from the bodywork, not envisaged by the Manufacturer, which has the purpose of sighting the intermediate split lines;
 - b)** installing or implementing viewfinders with adhesive material, inside or outside the vehicle, having dimensions larger than 15cm in length and 2 cm in width;
 - c)** the presence of adhesive viewfinders on race number plates, on the Organiser's advertising stickers and on race number plates.

7. RACE NUMBER AND STARTING ORDER

- 7.1** The assignment of race Numbers, valid also for drawing up the Starting Order in relation to the increasing order of the numbers assigned, excepting for specific organisational requirements, will comply with the following criteria:
- series 1: cars make OM;
 - series 2: cars in increasing order of year of manufacture.
- 7.2** Race numbers chosen at the discretion of the organiser can be assigned using specific procedures with public procurement procedures set up as required by the organiser.
- 7.3** The assignment of race numbers that follow one another can be requested, only for race cars that are part of the "Sponsor Team".
- The assignment of numbers will be as follows:
- a) division of cars into blocks of:
 - cars built pre 1945
 - cars built post 1945
 - b) inside each block, in the order according to the year of manufacture;
 - c) the positioning of the block of vehicles, in starting order, according to the average from the years of manufacture of the vehicles included in the same block.
- 7.4** Vehicles in the waiting list (Article 8.16) will leave according the race number assigned by the organiser who will, as far as possible, comply with the criteria stated in the previous points of this article.

8. ENTRIES

- 8.1** By signing the entry application form, the Competitor and Drivers undertake to submit only to the sporting jurisdictions recognised by the International Sporting Code and to the provisions of these SR.

Presentation of the entry form does not give the right to participate in the race as the organiser will select the requests and accept entries in his unquestionable judgement.

The organisers will not be required to motivate the reason for exclusion, nor will the said exclusion allow for the request for damages and/or refund of expenses, excepting for the return of the deposit (Art. 8.3 of these SR).

8.2 METHODS OF ENTRY

Entry applications may only be submitted via the Website.

The presentation date of each competitor's entry application coincides with the date on which the sum provided for in art. 8.3 below is credited to the bank account in the name of the Organiser. Entry must be formalized according to the days and times indicated in the Programme of these SRR.

Acceptance of the entry application will be announced to the Competitor according to the terms and conditions set out in these SRR.

8.3 ENTRY GUARANTEE DEPOSIT

- 8.3.1** Payment of Euro 15.250,00, or Euro 17.690,00, or Euro 21.960,00 or Euro 73.200,00 depending on the selected service package, valid as a deposit for entry of the car and team must be made in one of the following ways:

- a) by Credit Card (only VISA - MASTERCARD) by 16:00 (GMT+1) on Tuesday 16 January 2024;
- b) by bank transfer to the coordinates indicated in the entry form, with maximum credit value on the 1000 Miglia S.r.l. current account by 16:00 (GMT+1) on Tuesday 16 January 2024 .

For the entry to be valid, the crediting date onto the current account of 1000 Miglia S.r.l. is considered and not that of the payment mandate.

- 8.3.2** Teams that enter according to the provisions of sponsorship contracts as per Article 6.3 of these SRR will be subject to the following conditions of the said article:

- a) The closing date for presentation of entry and crediting of the bank transfer or payment by credit card will be Wednesday 24th January 2024 at 16:00 (GMT +1);
- b) the final deadline for crediting the entire amount of the deposit onto the current account of 1000 Miglia S.r.l., to be made by bank transfer or credit card, is Wednesday Monday 24th January 2024 without

prejudice to payments made within the above terms;

8.4 REQUEST FOR ENTRY OF A "SPONSOR TEAM"

In order to inform the Organizer of the willingness of a sponsor entitled to exercise the "Sponsor Team" option, the specific application form signed by the legal representative of the Sponsor must be sent, confirmed by e-mail by the Competitors of the identified cars, no later than 4:00 p.m. (GMT+1) on Monday 26th February 2024, to participants@1000miglia.it with a request for acceptance by the receiver and followed by confirmation of receipt by the receiver. Competitors with certified electronic mail (PEC) must send the abovementioned notice to the PEC address: 1000miglia@legalmail.it.

8.5 REQUEST TO ENTER A "GUEST CAR"

In order to inform the Organizer of the will of a Sponsor entitled to exercise the Guest Car option, the specific application form must be sent no later than 4:00 pm (GMT+1) on Monday 26th February 2024 to participants@1000miglia.it with a request for acceptance by the receiver and followed by confirmation of receipt by the receiver. Competitors with certified electronic mail (PEC) must send the abovementioned notice to the PEC address 1000miglia@legalmail.it.

8.6 METHOD TO PRESENT AND WITHDRAW THE REQUEST TO ENTER A SPONSOR "GUEST CAR"

In order to activate the "Guest Car" option for a vehicle belonging to a sponsor's quota, in addition to the provisions of article 8.5, the competitor must send to the organizer, according to the procedures and times indicated in the article 8.3.2, an additional security deposit equal to Euro 15.250,00 (Article 8.11 of these SRR), regardless of the number of drivers participating in the race.

8.7 ACCEPTABILITY OF ENTRY REQUESTS

Registration applications must be complete with all the documentation required by the application prepared by the organizer 1000 Miglia S.r.l. on its website www.1000miglia.it

Failure to pay the deposit means the request for entry will not be taken into consideration.

Requests which are untrue, incomplete, without documentation or with amounts owing to the organisation, will not be taken into consideration.

The organisation reserves the right not to accept vehicles whose drivers have been penalised in previous editions of the "1000 Miglia".

The organizer also reserves the right not to accept the entry of drivers who for three times during the previous year's race committed infractions of exceeding the speed limit set by the authorities in charge and detected by the Speed Test prepared by the Management Race.

8.8 ACCEPTANCE OF ENTRY

By Friday 12th April 2024, each team will be able to verify online, inside its own reserved area, whether or not the entry for the race has been accepted. Confirmation will nonetheless be sent also to the e-mail address indicated in the relative area of the entry form.

To complete entry, it will be necessary to enter the Bank details in the relative section of the on-line form, for the return of the fee, if necessary.

8.9 FINALISING ENTRY

Entry is understood as being finalised only on acceptance of the entry request by the organiser and to the allocation of the sum paid as a deposit in the sum paid as an entry fee.

After the car has been accepted at the event, 1000 Miglia S.r.l. will issue a regular invoice, using the data requested during the entry phase.

By presenting the request for entry, the applicant authorises the organiser to consider the amount paid previously as a deposit, as an entry fee in the case of acceptance of the request for entry.

8.10 ENTRY FEE

The following entry fees are envisaged:

8.10.1 BASIC ENTRY IN DOUBLE ROOM

The basic entry fee in a double room amounts to Euro 12,500.00 plus 22% VAT (total Euro 15,250.00) and includes:

- a) Participation in the race after selection of the car:
 - kit of documents and technical materials provided;
 - standard passes;

- 2 Welcome bags.
- b) Hospitality for a crew of two persons, including:
 - 4 nights (11th -12th -13th -14th June 2024) in a double room (not more than 4 stars) with breakfasts;
 - 4 light buffet lunches per person;
 - 4 light dinners per person;
 - Arrival lunch and Prize-giving ceremony for the driver and co- driver.
- c) Services included in the entry:
 - 4 Admissions to the Paddocks (including driver and co-driver and any mechanics / guests);
 - Possibility to purchase additional service packages.

8.10.2. SILVER 1000 MIGLIA ENTRY DOUBLE ROOMS

The Silver entry fee is Euro 14.500,00 plus 22% VAT (total Euro 17.690,00) and includes:

- a) Participation in the race after selection of the car:
 - kit of documents and technical materials provided;
 - "Silver" Pass;
 - 2 Silver Welcome bags with dedicated Merchandising
- b) Hospitality for a crew of two, including:
 - 6 nights (9rd -10th -11th -12th -13th -14th June 2024) in a hotel in a double room (category not exceeding 4 stars) with breakfast;
 - 4 light buffet lunches per person;
 - 4 light dinners per person;
 - Arrival lunch and Prize ceremony for driver and co-driver.
- c) Services included with entry:
 - 4 Accesses to the Paddock (including driver and co-driver and any mechanics / guests);
 - Dedicated check-in service at the Paddock (dedicated queues)
 - Possibility to purchase additional service packages.

8.10.3 GOLD ENTRY IN SINGLE ROOMS

The gold entry fee in a double room amounts to Euro 18,000.00 plus 22% VAT (total Euro 21,960.00)and includes:

- a) Participation in the race after selection of the car:
 - kit of documents and technical materials provided;
 - "Gold" passes;
 - 2 Welcome bags with dedicated Merchandising.
- b) Hospitality for a crew of two persons, including:
 - 6 nights (9rd -10th -11th -12th -13th -14th June 2024) in a single room (not more than 4 stars) with breakfasts;
 - 4 light buffet lunches per person;
 - 4 light dinners per person;
 - Arrival lunch and Prize-giving ceremony for the driver and co-driver.
- c) Services included in the entry:
 - 4 Admissions to the Paddocks (including driver and co-driver and any mechanics / guests);
 - Dedicated check-in service at the Paddock (dedicated queues);
 - 1000 Miglia 2024 Video Brochure or similar product sent to your residence after the event
 - Pre check-in service in hotels along the route (subject to the communication of credit card information and passport details by 15th May 2024);
 - Possibility to purchase additional service packages;

8.10.4. PLATINUM 1000 MIGLIA ENTRY "GUEST CAR" FORMULA

Available for a maximum of 8 entries accepted according in order of time together with the payment of the security deposit. The Platinum entry fee amounts to € 60,000.00 plus 22% VAT (total € 73,200.00) and includes:

- a) Participation in the race after selection of the car:
 - Automatic acceptance of the race without selection, after possession of an eligible vehicle (Article 6.6 of these SR);
 - Participation in the "Guest-Car" Formula Race - 6 admitted drivers with the right to exchange (Article 6.5 et seq. of this SR) and separate classification;
 - kit of documents and technical materials required for the car in the race;

- kit of documents and technical materials provided (Access Historical Centers) for the car in tow;
 - "Platinum" pass;
 - 6 Welcome bags Platinum with specific Merchandising.
- b) Hospitality for a crew of 6 people, including:**
- 7 nights (9rd -10th -11th -12th -13th -14th-15th June 2024) in 3 double-rooms (max. 6 people) – 5-star hotel (excluding Rome 4 stars) with breakfast;
 - 4 light lunches for 6 people;
 - 4 light dinners for 6 people;
 - Arrival lunch and Prize-giving ceremony for 6 people or Dinner at the respective Hotels;
- c) Services included in the entry:**
- 8 Admissions to the Paddocks (including driver and co-driver and any mechanics / guests);
 - Specific parking at the paddock;
 - 1000 Miglia 2024 Video Brochure or similar product sent to your residence after the event
 - Luggage transport to hotels along the route;
 - Dedicated check-in service at the Paddock (dedicated queues);
 - Pre-check-in service for hotels along the route (subject to credit card and passport delivery by 15th May 2024);
 - Possibility to purchase additional service packages.

8.11 ENTRY FEE SPONSOR "GUEST CAR"

The following entry fees are envisaged:

8.11.1 ENTRY FEE SPONSOR "GUEST CAR":

The extra- entry fee for the Basic Sponsor "Guest Car", in addition to the amount paid depending on the chosen service packages under Section 8.10, amounts to € 12,500.00 plus VAT 22% (total Euro 15.250,00) and includes, in addition to the services already listed in Article 8.10:

- a) Participation in the race of the car:**
- Participation in the "Guest-Car" Formula Race - 4 additional admitted drivers with the right to exchange (Article 6.5.3 et seq. of this SRR) and separate classification;
 - kit of documents and technical materials provided (Access Historical Centres) for the car following.
 - 4 Welcome bags aligned by type at the registration of the car for which the conversion into a Guest Car was requested.
- b) Hospitality for a crew of 4 persons, including:**
- 4 nights (13th-14th-15th -16th June) in 2 double rooms (max 4 persons) - hotel category not more than four stars with breakfasts;
 - 4 light buffets lunches per 4 people;
 - 4 light dinners for 4 people;
 - Pranzo di arrivo e Prize-giving ceremony for 4 people.
- c) Services included in the entry:**
- 4 Admissions to the Paddock;
 - Possibility to purchase additional service packages.

8.12 REFUND OF THE ENTRY FEE FOR CREWS NOT ACCEPTED

In the case of non-acceptance and/or non-inclusion on the waiting list of a car by the organiser, the deposit will be refunded by bank transfer or accredited on the credit card, by Monday 3rd June 2024.

8.13 HOW TO WITHDRAW THE APPLICATION FORM OR ENTRY

In all cases:

- the request for withdrawal of the entry application, i.e. the entry, must be sent by e-mail to participants@1000miglia.it with a request for acceptance by the recipient and followed by confirmation of receipt by the recipient himself. Competitors provided with certified e-mail (PEC) must send the abovementioned notice to the PEC address: 1000miglia@legalmail.it;
- if due, the refund of the entry fees will take place within 60 (sixty) days following the announcement date of the withdrawal.

8.14 REFUND OF THE ENTRY FEE IN CASE OF WITHDRAWAL OF THE ENTRY APPLICATION OR THE ACCEPTED ENTRY

Except as otherwise provided in Article 8.22 below, in the event of withdrawal, for any reason, of the entry application or the accepted entry by a Competitor, the entry fees shall be refunded only as follows:

From: opening date for entries To: closing date for entries	The fee paid as deposit by the Competitor shall be entirely refunded to the latter, net of administrative charges in the amount of Euros 200.00 plus VAT equal to 22%;
From: the day following the closing date for entries To: publication of list of Competitors and cars accepted	The fee paid as a deposit by the Competitor shall be entirely refunded to the latter, net of a penalty equal to Euro 1.250.00 (VAT exempt pursuant to article 15, paragraph 1, Italian Presidential Decree 633/72);
From: the day following the publication of the list of Competitors and cars accepted To: Wednesday 24 th April 2024	The entry fee paid by the Competitor will be refunded in full to the Competitor, less a deduction for secretarial and management fees of 50% of the fee paid plus VAT at 22%.
From: Thursday 25 th April 2024 To: Thursday 16 th May 2024	The entry fee paid by the Competitor will be refunded in full to the Competitor, less a deduction for secretarial and management fees of 75% of the fee paid plus VAT at 22%.
From: Friday 17 th May 2024	The entry fee shall not be refunded

8.15 FAILURE TO PASS ADMINISTRATIVE CHECKS

In the case of failure to pass the administrative checks and/or scrutineering, the competitor will not have the right to the refund of the entry fee paid, but will retain the right to make use of the hospitality envisaged for the team and any gifts and gadgets distributed directly by the sponsors, as per Article 8.10 et seq. of these SSR. This right shall be guaranteed only if the competitor or a crewmember with proxy signed by the competitor are present at the pre-race administrative checks. Therefore, if Competitors or drivers authorised by the same, are not present at the pre-race checks, they will not be entitled to the refund of the entry fee, nor will they be allowed to enjoy the hospitality provided for the crew or any benefitor facilities reserved to the participants.

8.16 WAITING LIST

The "Waiting List" is an instrument that allows the competitors entered for the event, but not accepted by the Organiser by the publication of the list of those admitted, to participate in the race by replacing crews that have withdrawn or have not passed the checks for any reason.

At the presentation of the request for entry, every competitor must state his acceptance to be placed on the "Waiting list".

The waiting list will be made up of the cars that:

- a) satisfy all eligibility requirements, as contained in these SR;
- b) have not been accepted as per the publication of the list of those admitted;
- c) belong to competitors who have provided their willingness to be part of such list.

Should a competitor accepted for the race as from publication of the list of competitors and cars admitted notify his withdrawal from the race, the organiser, at his sole discretion, will select one.

Competitors included in the Waiting List will have the possibility to accept or refuse the proposal by replying to participants@1000miglia.it within 72 hours from the announcement. Competitors provided with certified e-mail (PEC) must send the abovementioned notice to the PEC address: 1000miglia@legalmail.it.

Acceptance by the Organisation will allow the team to be registered for the race in compliance with Article 8.9 of these SR.

In case of non-acceptance by the Competitor of the proposal for participation, the amount paid by the Competitor as a guarantee deposit will be refunded in full net of secretarial costs of Euro 400,00 plus 22% VAT.

8.17 LIST OF CARS ON THE "WAITING LIST"

There are no lists for the cars on the waiting list. The replacement of crews that have withdrawn will be at

the unquestionable discretion of the organiser.

8.18 CLOSURE OF THE "WAITING LIST"

The "Waiting list" will close on Monday 3rd June 2024 at 16:00.

By the said date, the Organiser will inform those teams on the "Waiting list" whether they have been accepted for the race, or not, by e-mail directly to the address stated in the relative section of entry form.

8.18.1 The organiser has the right to contact competitors on the "Waiting List" in the case of withdrawal, from Tuesday 4th June to Monday 10th June 2024.

Competitors included in the Waiting List will have the possibility to accept or refuse the proposal by replying to participants@1000miglia.it within 24 hours from the announcement. Competitors provided with certified e-mail (PEC) must send the abovementioned notice to the PEC address: 1000miglia@legalmail.it.

Acceptance by the Organizer will result in the Crew entering the race in accordance with and for the purposes of Article 8.9 of these SRR.

In case of non-acceptance by the Competitor of the proposal for participation, the amount paid by the Competitor as a guarantee deposit will be refunded in full.

8.19 ADMISSION TO THE RACE DURING THE PRE-RACE VERIFICATION

Albeit without any guarantee of participating, competitors on the "Waiting list" will be able to be present at administrative checks on Tuesday 11th June 2024, from 07:30 to 08:30. After having entered, they have the possibility of being admitted to the race after scrutineering, at the unquestionable judgement and discretion of the organiser.

Acceptance can only take place in replacement of entered crews who have not passed scrutineering.

The crews coming from the "Waiting List" will not be entitled to any benefit or facilitation recognized to the participants, they will be entitled exclusively to the services related to the basic package as per art. 8.10.1). If the competitors accepted from the waiting list had paid the entry fee of the Silver or Gold package, the partial refund of the security deposit will take place within 60 days following the date of withdrawal and in any case no later than Friday 26th July 2024.

Acceptance will require the entry of the crew to the race, pursuant to and for the purposes of Article 8.9 of these SR.

8.19.1 The competitors who replace others during the scrutineering phase will be selected from among the registered crews, based on the following priority criteria:

- a) in substituting, priority will be given to a vehicle from the same period as the one substituted;
- b) with equal requisites, the competitor coming from further away will be selected.

8.20 NOTIFICATION OF WITHDRAWAL OF ENTERED CARS ON THE "WAITING LIST"

The withdrawal of the entry application by the competitor included in the Waiting List must be sent by e-mail to participants@1000miglia.it with a request for acceptance by the receiver and followed by confirmation of receipt by the receiver. Competitors with certified e-mail (PEC) must send the abovementioned notice to the PEC address 1000miglia@legalmail.it.

8.21 REFUND OF DEPOSIT FOR VEHICLES ON THE "WAITING LIST"

The refund of the deposit in the case of withdrawal by a competitor of a vehicle on the waiting list, will only occur in compliance with what is stated in Article 8.13 of these SR, applying administrative fees of Euro 400,00 plus VAT.

If owed, the deposit fee will be refunded within 60 days from the date of notification of the withdrawal, and nonetheless within and no later than Friday 26th July 2024.

It remains firm that competitors who do not withdraw and are not selected from the "Waiting List" have the right to be refunded in full for the amount paid by bank transfer or accredited on their credit card by Friday 26th July 2024.

8.22. POSTPONEMENT OF THE EVENT DUE TO FORCE MAJEURE

The Organiser reserves the right, at any time and at its sole discretion, to postpone the Event if an extraordinary event qualifying as a Force Majeure circumstance occurs, or, for the occurrence of extraordinary and unforeseeable events, not dependent on its will, which may directly or indirectly influence the ordinary running of the event, such as, but not limited to, health emergencies, epidemics, pandemics, measures taken by the Public Authorities, earthquakes, landslides, floods or, in general, any other natural

disaster that makes it impossible to hold all or part of the Event.

For any requests to withdraw entry, the conditions set out in art. 8.14 shall apply according to the new deadlines that will be communicated.

8.23 CANCELLATION OR SUSPENSION OF THE EVENT DUE TO FORCE MAJEURE

The Organiser reserves the right, at any time and at its sole discretion, to cancel and/or suspend the Event if an extraordinary event qualifying as a Force Majeure circumstance occurs, or, for the occurrence of extraordinary and unforeseeable events, beyond its control that may directly or indirectly influence the ordinary course of the event, such as, by way of example but without any limiting intent, health emergencies, epidemics, pandemics, measures by the Public Authorities, earthquakes, landslides, floods or, in general, any other natural calamity that makes it impossible to hold all or part of the Event.

In case of cancellation or suspension of the Race, the Organiser shall refund the entry fees as follows:

From: opening date for entries To: closing date for entries	The fee paid as a deposit by the Competitor shall be entirely refunded to the latter;
From the day following the closing date for entries To: Friday 3 th May 2024	The fee paid as a deposit by the Competitor shall be entirely refunded to the latter net of administrative charges in the amount of Euros 250.00 plus V.A.T. equal to 22%;
From: Saturday 4 th May 2024 To: Friday 24 th May 2024	The fee paid as a deposit by the Competitor shall be entirely refunded to the latter net of a deduction as administrative and management costs equal to 10% of the fee paid plus VAT at 22%
From: Saturday 25 th May 2024 To: Sunday 2 nd June 2024	The fee paid as a deposit by the Competitor shall be entirely refunded to the latter net of a deduction as administrative and management costs equal to 20% of the fee paid plus VAT at 22%
From: Monday 3 rd June 2024 To: Saturday 8 th June 2024	The entry fee shall be refunded to the extent of 50% plus VAT equal to 22%;
From: Sunday 9 th June 2024	The entry fee shall not be refunded

In case of postponement of the race, the aforementioned time limits will be extended.

Competitors included in the Waiting List shall be subject to the provisions of Article 8.21; Competitors who have not been accepted shall be subject to the provisions of Article 8.12 of these SRR.

9. GENERAL OBLIGATIONS

9.1 ADMINISTRATIVE CHECKS

Competitors and drivers must be present in person and with the accepted car, failure to do so will imply the impossibility of passing the checks and therefore of participating in the race, in the ways and means established in the programme. The Sports Inspectors and Road Traffic Police will undertake the following checks and formalities:

- a) checking of mandatory documents for competitors and drivers to be presented in original copy:
 - valid driving license, national and international;
 - sports licence of the nation of belonging or Italian daily licence;
 - medical certificate (Attached 1 of these SR);
 - valid race car insurance;
 - race car registration papers.
 - possible declaration of non-necessity of periodic revision of the vehicle according to the laws of the country of registration of the vehicle.
- b) hand out and apply the Personal Identification Device (CPI) described in Article 9.2 of these SR;
- c) sign, for acceptance, the check forms drawn up by the organiser and the Road Traffic Police;

The procedures for carrying out the administrative checks may be totally or partially dematerialised according to the anti COVID regulations prepared by the ASN and national or territorial government Bodies.

9.2 PRE ADMINISTRATIVE CHECKS AND SCRUTINEERING

The abovementioned documents must be uploaded by participants by 18 May 2023 into their reserved area of the entry system. Failure to upload even a part of the documents referred to in Article 9.1 may lead to penalisation of competitors up to exclusion from the race

9.3 PERSONAL IDENTIFICATION DEVICE (CPI)

During the administrative checks, a Personal Identification Device (CPI) will be applied to each driver, in

order to identify clearly the participant for the entire duration of the event.

The staff delegated by the organiser will be responsible for the application of this device and this cannot be refused by the driver.

The device cannot be ceded and cannot be removed until the end of the race on penalty of exclusion from the race.

The exhibition of the (CPI) can be requested by Officials or by escorting Road Traffic Police, at any moment. The absence of the sticker can result in the exclusion of the crew and the car from the race.

In the case of breakage or loss of the (CPI) the driver must first notify it to the first Competitor Relations Officer he finds along the route.

9.3.1 Only members of crews who have passed the pre-race administrative checks can participate in the race. No exchanges of authorised drivers are allowed between cars in the race.

Should persons other than those who have passed the pre-race administrative checks be found onboard a race car during the race, except for the transport of an injured person, the car and its driver will immediately be excluded from the race; this also does not exclude further penalties to be decided at the discretion of the Stewards.

9.4 RACE NUMBER STICKERS

At the administrative checks, each competitor will receive a Sticker Kit consisting of:

- 3 round number holder stickers, with the race number and the Organizer's advertising;
- 2 series of pre-spaced fluorescent race numbers.

9.4.1. APPLYING THE RACE STICKERS TO THE CARS

Cars must be presented for technical checks with all the kit stickers mentioned in Article 9.3 of these SRR already applied, according to the following instructions:

- a)** 1 round number holder sticker for each side of the race car on the front doors (in cars with doors) or on the front sides (on cars without doors or with small doors);
- b)** 1 round number holder sticker on the front bonnet of the race car;
- c)** 1 pre-spaced fluorescent number on the front windshield positioned to allow it to be seen when looking at the front part of the race car;
- d)** 1 pre-spaced fluorescent number on the rear window: should this not be possible the sticker must be applied on the rear boot in such a way as to allow it to be visible looking at the back of the race car;

The guide layout is provided attached to these SRR, for the correct positioning of the race numbers (Appendix 2).

Should it not be possible to apply all three of the round number holder stickers that are distributed, on the cars due to lack of space, it will be possible to apply only 2 stickers. In this case, the third sticker must be returned to the Organisation at the technical check, failure to do so could result in exclusion from the race.

9.5 SCRUTINEERING

After having passed all the administrative checks, the crews must submit the cars to scrutineering, in the ways and times stated in the programme. Failure to do so will lead to the cars being excluded from the race. Checks will be as follows.

- a)** check of the correct positioning of the stickers in compliance with Articles 9.3.1 of these SRR and check of the sound and light signals suitable for travelling on the road;
- b)** check of the following documents, to be presented as originals:
 - Registro 1000 Miglia Certificate
 - FIVA International Identity Card and/or FIA Heritage Certificate and/or valid ACI Sport Fiche and/or HTPFIA concerning the race car, all valid;
 - check that notified data correspond with registration data (year of manufacture and chassis number);
- c)** placing of safety equipment as per Article 9.6 of these SRR.

9.6 SEALING

At the end of the technical checks, each Competitor will be notified of the day and time when the cars tested must be driven, by the Competitor or his delegate, to the area in front of the paddock from where the escort will depart and take the cars to the stamping that will take place in Piazza Vittoria in Brescia.

Free entry is not allowed in Piazza Vittoria, competitors will be able to access the stamping area exclusively by following the escort prepared by the Organizer and carried out by the Brescia Local Police according to the following service hours:

- a) from 10:00 to 20:00 on Monday 12 June 2023;
- b) from 07:30 to 11:30 on Tuesday 13 June 2023.

Each competitor is required to respect the day and time assigned to them at the end of the technical checks for participation in the escort that will lead to the stamping.

During stamping, the Scrutineers will apply a "lead" to the steering column or another non movable part of the race car and will also apply a "Checked" sticker that cannot be removed, onto the car. Removal will result in the car being excluded from the race.

Once the Competitor has passed the sealing, they shall be considered to have been verified, accepted and to have started: any withdrawal from the competition, for any reason whatsoever, shall not entitle the Competitor to a refund of the entry fee and of any supplements purchased. The withdrawn crew may however continue to benefit from the hospitality services associated with the Event.

9.7 SAFETY EQUIPMENT

The GPS-Tracker equipment supplied by the organiser must remain installed on the racecar for the entire duration of the race. The equipment must be returned to the CO/TC at the final arrival.

The device will be pre-installed during the scrutineering by company engineers (a strip of Velcro will be applied on the vehicle to fix the device) and all necessary information as well as a use manual for the device will be provided, as well as a release form for the use of data recorded on the device itself.

The "GPS-Tracker" will track compliance to the route of the race by the team and will also record the speed of the car. Recorded data will be available to the race Directors and Stewards in order for them to take disciplinary action against the competitors who have broken the Road Safety Rules and the race regulations, aside from any other provisions that could be taken by Police Officers who have detected an infringement of the law. Data could be made available following a request by the legal authorities.

The data recorded by means of the GPS - Tracker equipment installed on all cars entered in the event shall be made available exclusively to the competent Public Authorities.

In the case of loss or malfunction of the GPS-Tracker, the competitor will notify this to the Competitor Relations Officer at every T.C. or those responsible for technical devices present at every lunch break and every arrival/start of each Leg.

In the case of withdrawal of a competitor along the route of the various Legs, the GPS-Tracker will be returned to the Competitor Relations Officers or to the persons responsible for this in the Technical Support Convoy (Technical Car and Pace Car).

9.8 OBLIGATIONS OF COMPETITORS - RULES OF CONDUCT

Throughout the event, drivers must drive prudently and carefully, scrupulously respect the Italian Road Traffic Law and instructions given by the Clerk of the course and by Officials.

The Officials - those in Charge (Article 2.4 of these SR) positioned in the Technical Support convoy (teams in the Front Car, Pace Car and Technical Car), Road Traffic Police Officers will notify violations and offences of the Regulations, and the Instructions stated above.

In the case of infringements, the Clerk of the course will notify the Stewards who will apply the following penalties:

- first offence: 1.000 negative penalty points;
- second offence: 12.000 negative penalty points;

Depending on the seriousness of the offence, the Stewards will apply the penalties up to exclusion from the event, even after only one offense.

In each Leg, the CoC can undertake speed checks on all the cars in the race. The Officials along the route as well as all the cars in the Technical Support convoy and Road Traffic Police Officers will also be responsible for supervising the conduct of the competitors and their service and team vehicles, notifying the Clerk of the course of any offence but without taking any independent decisions.

Also, Road Traffic Police Officers and local Police Members in the relative areas can notify the CoC of any offences by competitors and their service and team vehicles.

Driving behaviour should always be prudent for oneself, for Officials, and especially for spectators.

Each competitor is always responsible also for the behaviour of their service and team vehicles, which must necessarily strictly observe the instructions given by Officials and Marshals and must follow the route envisaged in the Road book in some parts of the race route. Failure to comply with this provision will result in sanctions against the relevant competitor, and may even lead to expulsion from the race, at the Stewards' discretion.

9.9 CHECKING OF PERSONAL IDENTIFICATION DEVICE (CPI)

For the entire duration of the event, the Officials on duty can ask the drivers to see their CPI. Drivers that cannot show their stickers could be expelled from the race by the Stewards.

10. RUNNING OF THE RACE

10.1 START

The cars will leave one at a time, from a stationary position with the engine running, 3 (three) cars departing every minute. Each car, once they have been given the "go", will have to free the Departure area as quickly as possible.

Under the control of Officials, departure may take place by pushing the car, if it fails to leave on its own.

Competitors must not stop the race car in the control areas (between the areas signalling the Start and End areas), exception being made for the check areas where the authorisation stamp will be printed by the Officials, reversing, changing direction, opening doors and in any way hindering the other teams will lead to the application of the penalty as stated in Article 12 of these SR.

The teams that do not make the CO/TC 1 Brescia - Departure Leg 1, will be penalized as specified in Article 12 of these SR for each missed transit check. Transit at CO/TC of the Leg 2 - Departure will still be mandatory, under penalty of exclusion.

Drivers must keep to the Official Times stated in the Itinerary Table. No restrictions will be imposed on them as regards the use of time recording equipment. The same may be synchronized with the clock placed at the start of each Leg, without direct connection to the said clock.

Any defect in detection of times, caused by any failure or malfunction of the equipment, will result, for the said checks, in the application of the average to each competitor and/or the annulment of the checks themselves for all competitors.

The organisers will state in the Road book, this will also be indicated on site, a straight stretch of road with measurements, used as the measured base in the preparation of the Road book, and competitors can verify this before the race.

10.2 TIME CONTROLS (CO/TC)

The purpose of the Time Control (CO/TC) is to outline the areas in which the route of the race is divided, in order to regulate the conduct of the same and to make sure the average speed is respected.

Each competitor (even when 3 cars a minute have been planned for) must be measured on the minute (e.g. for transit time 14:01 it will be possible to transit without penalty from 14:01:00 to 14:01:59).

The excesses as regards the ideal times established will determine the classification. Penalties for delays and early arrivals at a CO/TC are those stated in Article 12.1 of these SR.

Delays and early arrivals at a CO/TC must not be caught up in the next CO/TC. Teams must leave the "check area" free for transit. They are authorised to enter this area on board their car, in the minute preceding the ideal one for transit, and remain in the area for the time strictly necessary to record the transit time.

When the time is being read, the car must be inside the time reading area. During reading operations, at least one member of the team must be on board the race car.

The time used for the reading operation is not neutralised in any way. The reading is taken at the moment in which one member of the team hands over the Time Card to the Time-keeper.

If the race cars that are late or in advance of their ideal times transit through the CO/TC in the minute pertaining to cars on time, the Time-keeper will make a note, on the Time Card of the team that is late or in advance, of the real transit time, which corresponds to the start of the next sector, giving precedence, in the marking operations, to the team with the less delay on the ideal transit time.

All the CO/TCs will be appropriately marked with signs in compliance with the examples attached to these SR (Appendix 5).

Vehicles transiting through an OC/TC in the opposite direction or a direction other than the one decided by

the organiser will be excluded from the race.

10.3 TIME TRIALS (PC/TT)

Time Trials (PC/TT) are those timed areas of the route, between two consecutive readings where the drivers must keep to a set time indicated in the Itinerary Table and in the Time Card.

Readings will be done at 1/100th of a second without any tolerance. Differences in the ideal time will, as for the differences read at CO/TC, be used in determining the classification.

PC/TT will be undertaken with departure read at free entrance; the driver will be able to choose freely the start of the PC, nonetheless within approx. 5 seconds from the "all clear" given by the Marshals and/or the Timekeeper in charge.

Various consecutive PC/TTs will be envisaged (interconnected), where the time for passing to the final reading of the previous PC/TT will be the start time of the next PC/TT, and so forth.

For PC/TT located in equipped areas or temporary circuits, racetracks, kart-racing tracks, and for PC/TTs with lengths less than 300m, an appropriate map will be attached with the Road Book.

All PC/TTs will be properly marked both at the start and at the end, with signs in compliance with the examples attached to these SR (Appendix 6).

In the area of the route between the yellow sign and the beige sign showing the start and end of the measuring area, cars are not allowed to park, stop or open the doors. Should any cars stop in this measuring area due to a breakdown, they must be immediately removed according to the instructions given by the race official, on penalty of exclusion. Furthermore, unauthorised access by drivers and navigators is also forbidden.

Vehicles transiting through a PC/TC area in the opposite direction than the one decided by the organiser will be excluded from the race.

In the case of a lack or defect in the detection of one or more transits made by a Competitor in one or more PC/TTs, the Competitor will always be assigned a time relating to the missing PC/TT(s). The time assigned will be the result of the average of the PC/TTs actually played by the Competitor in the Leg in which the PC/TT(s) are missing or incorrectly recorded; the application will be made at the end of the Stage considered.

10.4 AVERAGE TRIALS (PM/AT)

Average Trials (PM/AT) are those sections of the route in a sector in which drivers must maintain a pre-established hourly average, indicated in the TDT and the Time Card.

For the purposes of the Trial classification, all the scores made by proceeding to the arithmetic sum of the scores taken from the "TABLE OF POINTS FOR THE AVERAGE TRIALS" attached to the Supplementary Regulations of the race will be considered; the total of the points will then be divided by the number of scores made in the Trial considered.

The Road book will indicate the starting place and the place that constitutes the theoretical maximum limit of the PM/AT end. In the sector between the beginning and the end of the PM/AT, the average is measured at one or more points not known by the driver: the TDT will indicate the number of measurements made for each PM/AT. For each average trial it will be possible to foresee up to 5 measurements.

The transit time will be recorded per second, rounded down, through the GPS-Tracker equipment installed at the pre-race checks. No objection is permitted against this finding.

10.4.1 START OF AVERAGE TRIALS

a. The PM/AT start will be "free start". Each PM/AT start will consist of two positions provided in the RB, located between 40 and 100 metres apart.

The first station, manned by Marshals whose task is to facilitate and regulate the departures of the cars, will be indicated by **a yellow background sign, with a waving flag**. The Marshals in charge will not record the time of passage of the cars on the Competitors' Time Card.

The second station, created to allow the best precision of the timing function of the GPS-tracking equipment by detecting the transit of the car already in motion, will not be manned by Marshals and will be indicated by **a red background sign with a waving flag**.

b. The competitor, once he has received an "all clear" signal from the marshals at the first station must proceed immediately, without stopping, to the second station and take the actual start for the PM/AT from the **Zero space/Zero time line corresponding to that station**. At this line, the competitor must start counting space and time in order to respect the imposed average assigned for each Trial.

c. In order to allow the competitor to reach the ideal average, there will be no measurements during the

first kilometre of each Trial.

d. No complaints will be accepted regarding any obstacles, difficulties or hindrances that may arise in the course of the PM/AT: each competitor must overcome them using his or her own means and abilities, while respecting the Road Traffic Regulations.

10.5 PASSAGE CONTROLS (CT/PC)

The purpose of the Passage Controls (CT/PC) is to check the strict adherence to the established route.

The opening and closing times of the CT/PC will be notified by the Clerk of the course Bulletin. At the CT/PCs, drivers must stop the cars in order for the check stamp or "all clear" stamp to be printed in the relative area of the Time Card. The absence of this stamp will mean exclusion.

All the CT/PC areas will be properly marked with signs in compliance with the examples attached to these SR (Appendix 6).

Vehicles transiting through a CT/PC area in the opposite direction or one other than the one decided by the Organiser will be excluded from the race.

10.6 ARRIVAL

Arrival check will be in Brescia – Piazzale Iveco and will be open from 12:30 on Saturday 15th June 2024.

After the arrival CO/TC, competitors will proceed following the instructions given by Marshals, to the arrival ramp.

11. MAXIMUM LATENESS

A crew will be over the maximum lateness:

- if it transits through a Time Control (CO/TC) with more than 30 minutes delay.
- if it accumulates delays through various Time Controls totalling more than 60 minutes delay.

Only at the starting CO/TC of each Leg will a crew be considered over the maximum time limit if they transit with more than 15 minutes of delay.

The opening and closing times of the Time Trials (PC/TT), the Average Trials (PM / AT) and of the Print Checks (CT/CP) will be notified through a Clerk of the course Bulletin.

12. PENALTIES AND DISCIPLINARY MEASURES

12.1 TIME CHECKS (CO/TC)

- for every minute or fraction thereof early: 100 negative penalty points
- for the first 2 minutes or fraction thereof late: 25 negative penalty points
- For more than 2 minutes and up to 5 minutes: 50 negative penalty points
- For delay of more than 5 minutes and up to 10 minutes: 100 negative penalty points
- Over 10 minutes and up to 20 minutes: 200 negative penalty points
- For over 20 and up to 30 minutes: 300 negative penalty points
- For each delay beyond the maximum time: 12,000 negative penalty points

12.2 TIME TRIALS (PC/TT)

- for each 1/100 of second early or late: 1 negative penalty point

12.3 SECRET TRANSIT CHECKS

- up to 20 minutes early: 320 negative penalty points
- more than 20 minutes early: 12,000 negative penalty points
- 2nd time more than 20 minutes early: exclusion

12.4 TIME CARD

- alterations, changes or corrections not endorsed by Officials: exclusion
- Failure to record a CO/TC: 12.000 negative penalty points
- Lack of a control stamp (CT/PC): 12.000 negative penalty points
- Failure to return to the CO/TC of Leg arrival: exclusion

12.5 OTHER PENALTIES

- refusal to start at the hour and in the set order: 100 negative penalty points
- stopping the car in the control area (stationary wheel): 100 negative penalty points
- unauthorised access of the crew in the check area

(subject to further action):	300 negative penalty points
• missing transit or time annotation at any control point:	12.000 negative penalty points
• unauthorized stopping in a control area:	12.000 negative penalty points
• blocking the passage and/or damaging other crews:	exclusion
• for non-sportsmanlike behaviour	from warning to exclusion
• for passage in a control area in a wrong or different direction:	exclusion
• for infringements of the Road Safety Rules:	up to exclusion
• document irregularities during administrative checks:	non-acceptance
• failure to comply with the checking times:	up to non-acceptance
• not starting at the first and the second Legs:	exclusion
• allowing a person other than a crew member to drive the car:	exclusion
• lack of a race number or race license plate:	fine
• lack of two or all of the race numbers:	exclusion
• failure to comply with provisions concerning the synchronization of chronometers:	up to exclusion
• for non-prudent behaviour of a crew member, or assistants or team car:	up to exclusion
• for leaning out of a moving car:	up to exclusion
• Failure to comply with the orders of Officials and Marshals:	up to exclusion
• Article 8.6 - first offense:	1.000 negative penalty points
• Article 8.6 - second offense:	12.000 negative penalty points
• infringements of the rules on advertising on cars in the race:	12.000 negative penalty points

13. CLASSIFICATION-PROTESTS AND APPEALS

13.1 CLASSIFICATION

The following classifications will be drawn up:

- a) overall classification;
- b) group classification;
- c) special classifications:
 - c1) by penalties;
 - c2) female crews (all members);
 - c3) for countries with at least 10 departing crews, compiled considering the sum of the 3 best individual results taken from the general Classification – excluding Italy;
 - c4) by crews and cars registered by the Armed Forces.
 - C5) "Sponsor Team" compiled by adding the individual scores of the Overall Classification obtained from the best 3 crews belonging to each Sponsor Team.
 - C6) "Guest Car"

13.2 COMPILATION AND PUBLICATION OF RESULTS

Classifications will be drafted on the basis of points scored by each crew in the PC/TT, in the PM/AT, the CO/TC and calculated according to the "points table" (Appendixes 7 and 8) and the coefficient assigned to each car (Appendix 7), deducting any possible negative penalty points.

"Differences" are not provided for.

The crew that receives the highest number of points will be declared the winner.

In case of a tie in the final classification, the winning position will be awarded to the crew/crews that has/have accumulated the least number of penalties, not points, during the race.

Those crews that do not transit or do not hand in the Time Card to the final arrival point, (the arrival of Leg 4), will not be classified.

The results will be published as per the Programme.

13.3 PROTESTS AND APPEALS

Protests and appeals must be submitted in the manner and within the terms established by the National Sporting Regulations.

- For each protest, the security deposit is € 350,00.
- For each appeal, the security deposit is € 3.000,00.

13.4 TERMS FOR SUBMISSION OF PROTESTS OR REQUESTS OF TIME CHECK

The classifications compiled at the end of Legs 1, 2 and 3 are to be considered final in the elements used to complete them. These classifications will be published 30 minutes before the start of each Leg: competitors

may submit a complaint (including a request of timing verification) against published documents, until the time of their individual starts by presenting a document with reasons for the dispute to the Competitor Relations Officers present at the start.

14. PRIZES

The event will have the following honour prizes:

- for the first 30 crews of the overall classification (prizes for both crew members);
- for the first 3 classified of the group classification (prizes for both crew members);
- for the first 3 classified of entirely female crews (classification c2) (prizes for both crew members);
- for those placed first in the classification by nations (c3 classification): one prize for the first, one for the second and one for the third placed nation;
- for the first place in other special classifications:
 - Penalties (classification c1): prizes for both crew members;
 - Armed Forces (classification c4): prizes for both crew members;
 - Sponsor Team (classification c5): a single prize, for first place;
 - Guest Car (classification c6): a single prize, for first place.

Prizes are not cumulative, therefore the winners of more than one classification will be awarded to prize for the most important classification.

Crews that are not present at the prize giving will forfeit their prizes without the classification being changed.

15. GENERAL RULES

15.1 RESPONSIBILITIES

By the very act of entering for this event, each competitor declares for themselves and their drivers, for the staff on their own service vehicles and accompanying vehicles, for their dependents and assignees:

- to recognize and accept the provisions of the National Sporting Regulations (and Sector Rules) and the present SR, committing themselves to respect and to enforce them;
- under their direct responsibility, to have their Drivers, their assistance personnel, employees and appointees sign these SRR for acceptance, which shall be strictly observed;
- to relieve the Italian Automobile Club, the ACI Sport, the ACI Brescia, the Organiser 1000 Miglia S.r.l. and all persons involved in the organisation, as well as the Automobile Clubs involved in the event, the Local Authorities involved, the Officials and the owners of the routes where the race takes place from any liability regarding any damages to competitors, or their drivers, navigators, employees and agents, or things, or produced or caused to third parties or of objects by the competitor himself, his drivers, navigators, employees and agents.

15.2 DISPUTES

Competitors undertake to resolve any dispute of a patrimonial nature that may arise due to facts arising from the application and/or interpretation of these SRR and from the course of the Event by means of the sports arbitration provided for in articles 236 et seq. of the National Sporting Regulations and the ACI Sporting Justice Regulations for disputes of a sporting nature that occurred during the Event. All disputes of a technical and disciplinary nature definitively decided by the Organiser and/or its own bodies that have given rise to penalisation or exclusion from the Event rankings or to financial penalties are expressly excluded from the sporting arbitration;

15.3 ADVERTISING

No form of advertisement may be placed on the car, unless this is expressly provided for by the organiser, which will be announced by a special information bulletin, in compliance with the provisions of current ACI Sport legislation.

Competitors whose cars were entered by the Sponsor in the "Sponsor Team", can exhibit on the sides of their cars, a logo or wording having maximum dimensions of 10 x 20 cm or similar.

The accepted logo or wording can echo the commercial Trademark of the sponsor and can appear on race cars belonging to each mentioned "Sponsor Team" and will in any case be subject to prior authorisation by the Organiser.

The number of authorised race cars for each Sponsor, will be determined by the agreements signed between the Organiser and the Sponsor itself.

To obtain the Organiser's authorisation, each interested Sponsor must submit the planned artwork and state

which motor cars will be part of his "Sponsor Team" sending his request within and no later than Thursday 16th May 2024, to the following address: participants@1000miglia.it

The names of the crewmembers can be written on each of the sides of the race cars in the maximum dimension of 10 x 40 cm per side.

A Club logo, not having advertising purpose (all or part thereof), can appear on each side of race cars occupying a maximum space of 10 x 10 cm, per side or equivalent surface.

The original livery is tolerated as regards identification badges, even if they constitute advertising, limited however to what was originally used for that specific vehicle identified with the chassis number.

Any form of advertising that does not correspond to what is stated in this article will be removed by the Organiser and/or by Officials who will carry out checks before and during the race.

The breach of the provisions of this article will be sanctioned with 12,000 negative penalty points. Those crews that will be found non-compliant with the provisions set forth above will be denied participation in future editions of the event. The organiser reserves the right to charge the offending crew with damages resulting from the contravention of this Article.

The participants therefore agree to assume the obligation to pay compensation for all damages suffered by the organiser and third parties in general, relieving the same from any liability, for any and all liability and/or damages resulting from the violation of the abovementioned prohibition.

15.4 RACE NUMBER PLATES

All the race numbers (plates) handed over by the Organiser to the competitor must be attached to the race cars. The discovery of one of the delivered race number plates on a car other than the race car, will lead to a penalty that could result in the immediate exclusion of the same race car from the race.

15.5 OTHER PLATES PROVIDED BY THE ORGANIZER

All cars with race number plates of the 1000 MIGLIA 2024 event applied, bearing the wording of function:

- Race number 500
- Race number 1000
- ORGANIZATION
- MEDIA
- MEDIA PARTNER
- SPONSOR and SPONSOR GUEST
- FRIENDS
- CHARITY
- GUEST CAR

being part of the race convoy and also authorized to transit on roads temporarily closed to ordinary traffic are cars and crews not in the race and always travel under the responsibility of their owners and drivers.

16. INSURANCE

16.1 Introductory remarks

The entry fee includes the insurance premium for the competitors' civil liability to third parties for risks arising from circulation during the rally, along the route (fixed route and/or alternative) described in the Road book or in RG2 or given out by Bulletins and Clerk of the Course Communications.

16.2 Damages covered by the insurance

The Insurance Policy of the organiser is covering only the damages caused to third parties or properties of third parties by the organiser or by drivers entered in the rally. Any other damage suffered by the drivers, co-drivers or vehicles entered in the rally are not covered by the insurance.

16.3 Organisers' responsibility

The organiser decline liability for any accident suffered by competitors or competing cars during the duration of the entire event, even in case of cataclysm, riots, demonstrations, vandalism, etc. Competitors and crew members shall suffer all the consequences (material, criminal and sporting) raised by any type of accident.

16.4 Insurance coverage

The maximum amount covered by the Insurance Policy is € 25,000,000.00 for each accident for damages to persons and for damages to goods.

16.5 Duration of the insurance coverage

This insurance, for all competitors, will become effective at the start of procedure for car scrutineering. The insurance ceases at the end of the event or at the end of the event or, in case of withdrawal, disqualification

or exclusion from the race, at the time taken into account will be the closing time of the following TC.

16.6 Accident notification

In case of an accident the competitor or his representative must immediately notify it to the Clerk of the Course. Place, circumstances under which the accident occurred, causes and consequences must be described. Likewise, the names and addresses of any witness or injured person must be indicated.

17. APPENDIXES

The following appendixes are an integral part of these SR:

- **APPENDIX 1:** Facsimile of the Medical Certificate for non-competitive sports activities;
- **APPENDIX 2:** Positioning of race numbers on the cars;
- **APPENDIX 3:** Itinerary Table: (the definitive Itinerary Table will be communicated with the Road book);
- **APPENDIX 4:** Maps of the route: (will be communicated with the Road book);
- **APPENDIX 5:** Signage Posters of Checks;
- **APPENDIX 6:** Coefficient Table;
- **APPENDIX 7:** Points table for the Time Trial (TT);
- **APPENDIX 8:** Points table for the Average Tests (AT)

Supplementary Regulations for the Grande Evento for historic cars to be held on 9th/15th June 2024 called 1000 MIGLIA 2024

The organizer declares the commitment to verify that all those who will participate in the competition, but are not included in this SRR, will be holders of a valid sports license issued by the Federation.

The carrying out of the tender is in any case subject to the release of the authorization by the Italian Ministry of Transport, as provided for by the art. 9, paragraph 4, Italian Street Code.

This SRR and the related permission to organize may be revoked at any time in the event of violation by the Organizer of the art. 56 of the RNS.

The Clerk of the course
(has read and accepts the appointment)

Mr. *Lucio DE MORI*

The legal representative of the Organising Body

Mr. *Alberto PIANTONI*

For the Regional Delegation

Mr. *Alessandro TIBILETTI*

SEEN AND APPROVED
THE SECRETARY OF ACI SPORTS BODIES
Mr. Marco FERRARI

These SR have been approved on _____ with approval number AS _____.

Attachment 1: Facsimile Medical Certificate for non-competitive Sporting Activities

Certificato di idoneità alla pratica di attività sportiva di tipo non agonistico
Certificat d'aptitude à la pratique d'un sport non professionnel
Medical certificate for non-competitive sport activity

Sig. - Sig.ra \ Mons. - Mme \ Mr. - Mrs: _____

nato - nata a \ né à \ born in: _____

il \ le \ on: _____

indirizzo \ adresse \ address: _____

Il soggetto, sulla base della visita medica da me effettuata, dei valori pressione arteriosa rilevati, nonché dal referto del tracciato ECG eseguito in data _____

non presenta controindicazioni in atto alla pratica di attività sportiva non agonistica.

(Decreto del Ministro della Salute del 24 aprile 2013; Legge del 9 agosto 2013, n. 98, art. 42-*bis*; Legge 30 ottobre 2013, n. 125, art. 10 - *septies*; Decreto del Ministero della Salute dell'8 agosto 2014)

Based on a physical examination, including blood pressure readings, and from the results of the ECG test, carried out on _____

I hereby declare my client is in good health and fit to practice non-competitive sport activities

Sur la base d'un examen médical réalisé par mes soins, des valeurs de la pression artérielle relevées ainsi que du résultat du test ECG effectué le _____

le patient ne présente pas de contre-indication à la pratique d'activités sportives non professionnels.

Il presente certificato ha validità annuale dalla data del rilascio

Ce certificat est valable 1 an

This certificate is valid for a period of one year

Luogo | Lieu | Issued in: _____ il | le | on: _____

Il Medico \ le Medecin \ the Doctor (*firma e timbro - signature et tampon - signature and stamp*):

Attachment 2: Posting of Race Numbers on the cars

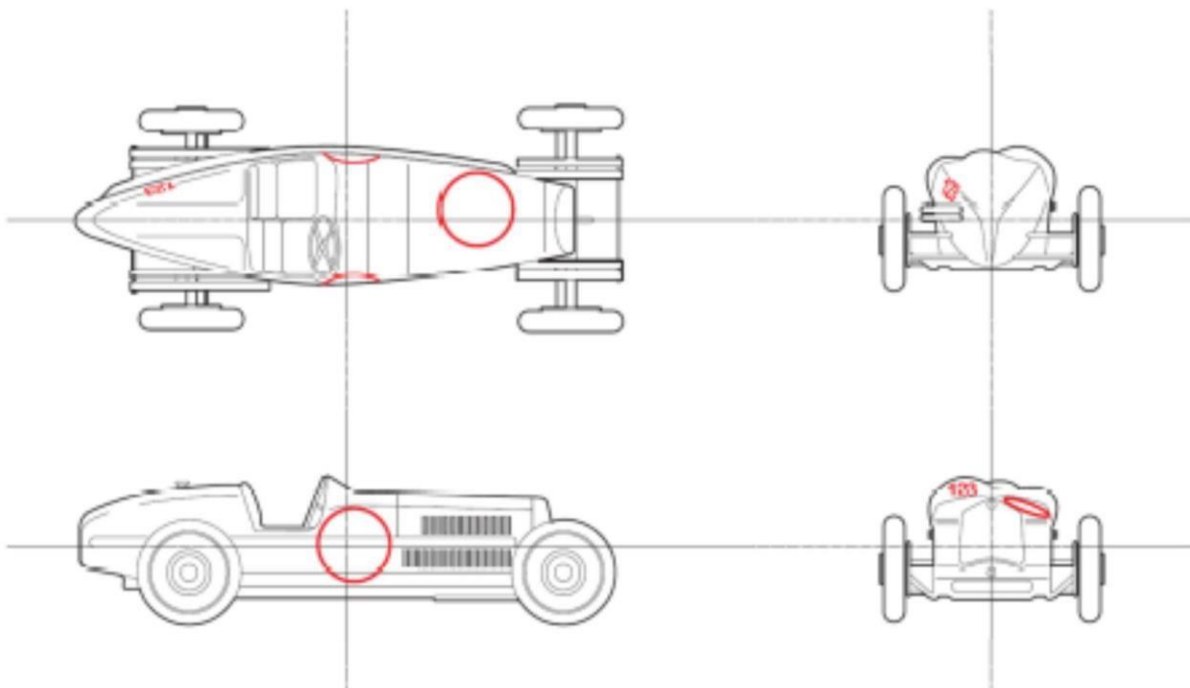
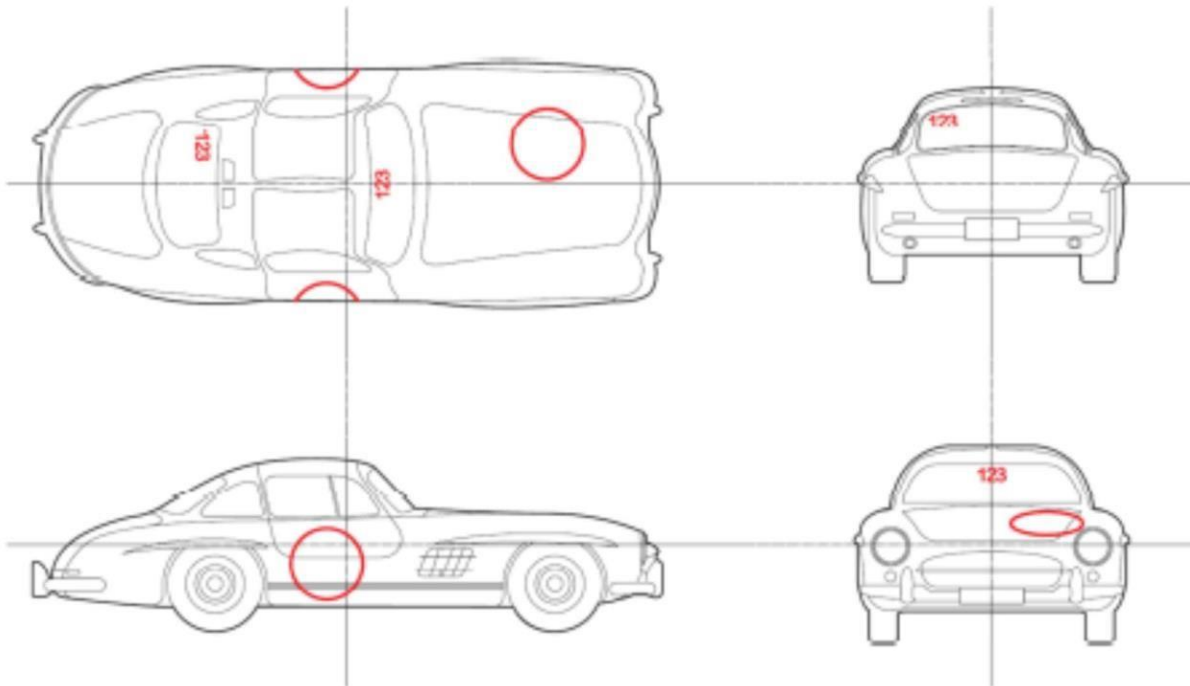

Attachment 3: Itinerary, Times and Distance Table

(The TDT will be distributed together with the Road book)

Attachment 4: Maps of the route

1000 MIGLIA 2024
A WAY OF LIVING

11 - 15 GIUGNO 2024

1ª Tappa / MARTEDÌ 11
Brescia → Torino

↳ **2ª Tappa / MERCOLEDÌ 12**
Torino → Viareggio

↳ **3ª Tappa / GIOVEDÌ 13**
Viareggio → Roma

↳ **4ª Tappa / VENERDÌ 14**
Roma → Bologna

↳ **5ª Tappa / SABATO 15**
Bologna → Brescia

DISCOVER MORE
1000miglia.it

f X Instagram YouTube

1000 MIGLIA SRL

Attachment 5: Control Signs

CARTELLI DEI CONTROLLI - CONTROL SIGNS

CO / TC*	INIZIO ZONA CONTROLLO • CONTROL AREA START 	CONTROLLO • CONTROL 	FINE ZONA CONTROLLO • CONTROL AREA END
	GIALLO/YELLOW mt 25 circa - approx.	ROSSO/RED mt 25 circa - approx.	BEIGE mt 25 circa - approx.
CT / PC**			
	GIALLO/YELLOW mt 25 circa - approx.		
CO / TC*	INIZIO ZONA CONTROLLO • CONTROL AREA START 	CONTROLLO • CONTROL 	FINE ZONA CONTROLLO • CONTROL AREA END
	GIALLO/YELLOW mt 25 circa - approx.	ROSSO/RED mt 25 circa - approx.	BEIGE mt 25 circa - approx.
PC*** SINGOLE O CONCATENATE LUNGHEZZA INFERIORE / UGUALE A 300 MT.	INIZIO ZONA CONTROLLO • CONTROL AREA START 	CONTROLLO • CONTROL 	FINE ZONA CONTROLLO • CONTROL AREA START
	GIALLO/YELLOW mt 25 circa - approx.	ROSSO/RED lunghezza inferiore/uguale - length inferior/equal to 300mt.	BEIGE lunghezza inferiore/uguale - length inferior/equal to 300mt.
TT**** SINGLE OR CONNECTED LENGTH INFERIOR / EQUAL TO 300 MT.	INIZIO ZONA CONTROLLO • CONTROL AREA START 	CONTROLLO • CONTROL 	FINE ZONA CONTROLLO • CONTROL AREA START
	GIALLO/YELLOW mt 25 circa - approx.	ROSSO/RED lunghezza inferiore/uguale - length inferior/equal to 300mt.	BEIGE lunghezza inferiore/uguale - length inferior/equal to 300mt.
PC*** SINGOLE O CONCATENATE LUNGHEZZA SUPERIORE A 300 MT.	INIZIO ZONA CONTROLLO • CONTROL AREA START 	CONTROLLO • CONTROL 	FINE ZONA CONTROLLO • CONTROL AREA START
	GIALLO/YELLOW mt 25 circa - approx.	ROSSO/RED mt 25 ca - approx.	BEIGE mt 25 circa - approx.
TT**** SINGLE OR CONNECTED LENGTH SUPERIOR TO 300 MT.	INIZIO ZONA CONTROLLO • CONTROL AREA START 	CONTROLLO • CONTROL 	FINE ZONA CONTROLLO • CONTROL AREA START
	GIALLO/YELLOW mt 25 circa - approx.	ROSSO/RED mt 25 circa - approx.	BEIGE mt 25 circa - approx.
PM PROVA DI MEDIA CON UNO O PIU' CONTROLLI SEGRETI	INIZIO ZONA CONTROLLO • CONTROL AREA START 	CONTROLLO • CONTROL 	FINE ZONA CONTROLLO • CONTROL AREA START
	GIALLO/YELLOW mt 25 circa - approx.	ROSSO/RED estensione della prova di media / extension of average test	BEIGE estensione della prova di media / extension of average test
AT AVERAGE TEST WITH ONE OR MORE SECRET CONTROLS	INIZIO ZONA CONTROLLO • CONTROL AREA START 	CONTROLLO • CONTROL 	FINE ZONA CONTROLLO • CONTROL AREA START
	GIALLO/YELLOW mt 25 circa - approx.	ROSSO/RED estensione della prova di media / extension of average test	BEIGE estensione della prova di media / extension of average test
LIMITE DELL'ESTENSIONE DELLA PM - LIMIT AT EXTENTION			
INIZIO ZONA CONTROLLO • CONTROL AREA START 			
CONTROLLO • CONTROL 			
INIZIO ZONA CONTROLLO • CONTROL AREA START 			
CONTROLLO • CONTROL 			
FINE ZONA CONTROLLO • CONTROL AREA END 			
LIMITE DELL'ESTENSIONE DELLA PM - LIMIT AT EXTENTION			

***Ai Controlli Orari NON SEGUITI da Start Prova Cronometrata**

Le vetture sono autorizzate ad entrare nella zona di controllo (tra il cartello giallo e quello rosso di controllo) nel minuto che precede il loro minuto teorico di transit (solo se la zona è già stata liberata dalle vetture che precedono) oppure nel loro minuto teorico di transit e devono consegnare la tabella di marcia al cronometrista, per l'annotazione dell'orario di transit. I membri dell'equipaggio sono autorizzati a rimanere a bordo della vettura.

****Ai Controlli Timbro**

I membri dell'equipaggio devono rimanere a bordo della vettura e consegnare al commissario la tabella di marcia, per l'apposizione del timbro, senza iscrizione dell'orario di transit; la sosta nella zona deve essere limitata all'operazione di timbratura.

*****Nelle Prove Cronometrate**

Tra il cartello giallo di inizio ed il cartello beige di fine zona controllo è vietato l'arresto (fermo vettura/fermo ruote) e la sosta della vettura.

***At the Time Controls NOT FOLLOWED by Start Time Trials**

The cars are authorized to enter the control area (between the yellow and red control sign) in the minute preceding their theoretical transit minute (only if the area has already been freed from the cars ahead) or during their theoretical transit minute and must hand in the time card to the timekeeper, in order for him to note down the transit time. Crew members are allowed to remain on board the car.

****During the Time Trials**

Between the yellow sign at the beginning and the beige sign at the end of the control area, it is forbidden to stop (vehicle stopped/wheels stopped) and park the car.

*****At the Stamp Controls**

The crew members must remain on board the car and hand in the time card to the Marshal, where he will put the stamp, without inscription of the transit time; parking in the area must be limited only to the stamping operation.

Attachment 6: Coefficient table



- ➔ In **ROSSO** sono riportate le vetture che hanno vinto un'edizione della 1000 Miglia dal 1927 al 1957.
RED shows cars that have won an edition of the Mille Miglia from 1927 to 1957.
- ➔ **WOA** - Winner Overall: tutte le vincitrici assolute hanno coefficiente 1,80. All the overall race winners have a coefficient of 1.80.
- ➔ Vincitrici di Classe / Class Winner: alle vetture vincitrici di Classe o Categoria in una edizione delle 1000 Miglia 1927/1957 viene aggiunto al coefficiente il "Fattore MM", pari a + **0,05**.
 The "MM Factor", equal to + **0.05**, is added to the winning cars of Class or Category in an edition of the 1000 Miglia 1927/1957.

	MARCA MARQUE	MODELLO MODEL	COEFF. Multiplier	CALCULATION FACTOR						WINNER FACTOR
				PERIOD	CLASS	CAT.	PERIOD	CLASS	CAT.	
1	A.L.F.	Ardea 750 barchetta	1,35	1950-1952	<750	S	0,15	0	0,20	0
2	A.L.F.	Ardea 750 siluro	1,35	1950-1952	<750	S	0,15	0	0,20	0
3	A.L.F.	Ardea 750 spider	1,40	1947-1949	<750	S	0,20	0	0,20	0
4	A.L.F.	S.I.A.T.A. TC motore Ardea 750	1,30	1953-1957	<750	S	0,10	0	0,20	0
5	A.S.G.	SVA - Giannini 750	1,35	1950-1952	<750	S	0,15	0	0,20	0
6	ABARTH	600 FIAT	1,10	1953-1957	<750	T	0,10	0	0	0
7	ABARTH	750 Vignale	1,20	1953-1957	<750	GT	0,10	0	0,10	0
8	ABARTH	Cisitalia 204	1,65	1947-1949	<1100	SC	0,20	0,10	0,35	0
9	ABARTH	Cisitalia 204 A	1,60	1950-1952	<1100	SC	0,15	0,10	0,35	0
10	ABARTH	Cisitalia 204 A siluro	1,65	1947-1949	<1100	SC	0,20	0,10	0,35	0
11	ABARTH	Cisitalia 204 A spider	1,60	1950-1952	<1100	SC	0,15	0,10	0,35	0
12	ABARTH	Cisitalia 205 berlina Vignale	1,60	1950-1952	<1100	SC	0,15	0,10	0,35	0
13	ABARTH	FIAT 1100 S	1,60	1950-1952	<1100	SC	0,15	0,10	0,35	0
14	ABARTH	FIAT 1400 berlina Touring	1,40	1950-1952	>1101	GT	0,15	0,15	0,10	0
15	ABARTH	FIAT 750 Berlina	1,25	1953-1957	<750	GT	0,10	0	0,10	0,05
16	ABARTH	FIAT 750 Berlina Zagato	1,25	1953-1957	<750	GT	0,10	0	0,10	0,05
17	A.C.	Ace	1,40	1953-1957	>1101	SP	0,10	0,15	0,15	0
18	A.C.	Aceca Bristol Coupé	1,35	1953-1957	>1101	GT	0,10	0,15	0,10	0
19	ALA D'ORO	Stanguellini FIAT 1100 spider	1,50	1947-1949	<1100	S	0,20	0,10	0,20	0
20	ALCA	Volpe 124 cm3	1,40	1947-1949	<750	S	0,20	0	0,20	0
21	ALFA ROMEO	RL SS torpedo Zagato	1,70	1927-1929	>1101	S	0,35	0,15	0,20	0
22	ALFA ROMEO	RL SS torpedo	1,70	1927-1929	>1101	S	0,35	0,15	0,20	0
23	ALFA ROMEO	6C 1500	1,45	1930-1934	>1101	T	0,30	0,15	0	0
24	ALFA ROMEO	6C 1500 S	1,70	1927-1929	>1101	S	0,35	0,15	0,20	0
25	ALFA ROMEO	6C 1500 Sport Spider Zagato (winner 1928)	1,80	1927-1929	>1101	SS	0,35	0,15	0,25	WOA
26	ALFA ROMEO	6C 1500 SS	1,80	1927-1929	>1101	SS	0,35	0,15	0,25	0,05
27	ALFA ROMEO	6C 1500 MMS	1,80	1927-1929	>1101	SS	0,35	0,15	0,25	0,05
28	ALFA ROMEO	6C 1500 SS siluro Ghia	1,75	1927-1929	>1101	SS	0,35	0,15	0,25	0
29	ALFA ROMEO	6C 1500 SS	1,75	1930-1934	>1101	SS	0,30	0,15	0,25	0,05
30	ALFA ROMEO	6C 1500 SS spider Brianza	1,70	1930-1934	>1101	SS	0,30	0,15	0,25	0
31	ALFA ROMEO	6C 1500 SS spider Campari & Sornioti	1,70	1930-1934	>1101	SS	0,30	0,15	0,25	0
32	ALFA ROMEO	6C 1500 SS spider Carr. Sport	1,70	1930-1934	>1101	SS	0,30	0,15	0,25	0
33	ALFA ROMEO	6C 1500 SS spider Ghia	1,70	1930-1934	>1101	SS	0,30	0,15	0,25	0
34	ALFA ROMEO	6C 1500 Gran Sport	1,75	1930-1934	>1101	SS	0,30	0,15	0,25	0,05

	MARCA MARQUE	MODELLO MODEL	COEFF. Multiplier	CALCULATION FACTOR						WINNER FACTOR
				PERIOD	CLASS	CAT.	PERIOD	CLASS	CAT.	
35	ALFA ROMEO	6C 1750 SS (winner 1929)	1,80	1927-1929	>1101	SS	0,35	0,15	0,25	WOA
36	ALFA ROMEO	6C 1750 GS Spider Zagato (winner 1930)	1,80	1930-1934	>1101	SS	0,30	0,15	0,25	WOA
37	ALFA ROMEO	6C 1750	1,45	1930-1934	>1101	T	0,30	0,15	0	0
38	ALFA ROMEO	6C 1750 GS	1,70	1930-1934	>1101	SS	0,30	0,15	0,25	0
39	ALFA ROMEO	6C 1750 GS a gasogeno	1,65	1930-1934	>1101	S	0,30	0,15	0,20	0
40	ALFA ROMEO	6C 1750 GT	1,60	1930-1934	>1101	GT	0,30	0,15	0,10	0,05
41	ALFA ROMEO	6C 1750 GT berlina Touring	1,55	1930-1934	>1101	GT	0,30	0,15	0,10	0
42	ALFA ROMEO	6C 1750 GT cabriolet Castagna	1,55	1930-1934	>1101	GT	0,30	0,15	0,10	0
43	ALFA ROMEO	6C 1750 S	1,60	1927-1929	>1101	GT	0,35	0,15	0,10	0
44	ALFA ROMEO	6C 1750 S torpedo	1,55	1930-1934	>1101	GT	0,30	0,15	0,10	0
45	ALFA ROMEO	6C 1750 S	1,60	1930-1934	>1101	GT	0,30	0,15	0,10	0,05
46	ALFA ROMEO	6C 1750 GS spider Brianza	1,70	1930-1934	>1101	SS	0,30	0,15	0,25	0
47	ALFA ROMEO	6C 1900	1,40	1935-1940	>1101	T	0,25	0,15	0	0
48	ALFA ROMEO	6C 2300	1,55	1935-1940	>1101	SP	0,25	0,15	0,15	0
49	ALFA ROMEO	6C 2300 B berlina	1,55	1935-1940	>1101	SP	0,25	0,15	0,15	0
50	ALFA ROMEO	6C 2300 B MM berlina Ghia	1,55	1935-1940	>1101	SP	0,25	0,15	0,15	0
51	ALFA ROMEO	6C 2300 B MM berlina Touring	1,60	1935-1940	>1101	SP	0,25	0,15	0,15	0,05
52	ALFA ROMEO	6C 2300 B motore 2500 SS	1,60	1935-1940	>1101	S	0,25	0,15	0,20	0
53	ALFA ROMEO	6C 2300 B MM spider Touring	1,65	1935-1940	>1101	S	0,25	0,15	0,20	0,05
54	ALFA ROMEO	6C 2300 GT berlina	1,50	1935-1940	>1101	GT	0,25	0,15	0,10	0
55	ALFA ROMEO	6C 2300 GT spider	1,50	1935-1940	>1101	GT	0,25	0,15	0,10	0
56	ALFA ROMEO	6C 2300 Pescara Touring	1,50	1935-1940	>1101	GT	0,25	0,15	0,10	0
57	ALFA ROMEO	6C 2300 Pescara berlina Touring	1,60	1935-1940	>1101	SP	0,25	0,15	0,15	0,05
58	ALFA ROMEO	6C 2300 Pescara spider	1,50	1935-1940	>1101	GT	0,25	0,15	0,10	0
59	ALFA ROMEO	6C 2300 Pescara spider Zagato	1,50	1935-1940	>1101	GT	0,25	0,15	0,10	0
60	ALFA ROMEO	6C 2300 Pescara Sport Spider Touring	1,60	1935-1940	>1101	S	0,25	0,15	0,20	0
61	ALFA ROMEO	6C 2500	1,60	1935-1940	>1101	S	0,25	0,15	0,20	0
62	ALFA ROMEO	6C 2500 SS spider Touring corsa	1,70	1935-1940	>1101	SS	0,25	0,15	0,25	0,05
63	ALFA ROMEO	6C 2500 SS spider corsa	1,65	1935-1940	>1101	SS	0,25	0,15	0,25	0
64	ALFA ROMEO	6C 2500 SS spider Albanesi	1,55	1947-1949	>1101	S	0,20	0,15	0,20	0
65	ALFA ROMEO	6C 2500 SS spider	1,55	1947-1949	>1101	S	0,20	0,15	0,20	0
66	ALFA ROMEO	6C 2500 SS spider Pinin Farina	1,55	1947-1949	>1101	S	0,20	0,15	0,20	0
67	ALFA ROMEO	6C 2500 SS Spider Colli	1,65	1947-1949	>1101	SS	0,20	0,15	0,25	0,05
68	ALFA ROMEO	6C 2500 SS coupé Touring	1,55	1947-1949	>1101	S	0,20	0,15	0,20	0
69	ALFA ROMEO	6C 2500 berlina	1,35	1947-1949	>1101	T	0,20	0,15	0	0
70	ALFA ROMEO	6C 2500 S cabriolet Pinin Farina	1,45	1947-1949	>1101	GT	0,20	0,15	0,10	0
71	ALFA ROMEO	6C 2500 SS "torpedino Brescia"	1,55	1947-1949	>1101	S	0,20	0,15	0,20	0
72	ALFA ROMEO	6C 2500 SS cabriolet Pinin Farina	1,55	1947-1949	>1101	S	0,20	0,15	0,20	0
73	ALFA ROMEO	6C 2500 Competizione	1,65	1947-1949	>1101	SS	0,20	0,15	0,25	0,05
74	ALFA ROMEO	6C 2500 Freccia Oro	1,40	1950-1952	>1101	T	0,20	0,15	0	0,05
75	ALFA ROMEO	6C 3000 C50 berlina Touring	1,65	1950-1952	>1101	SC	0,15	0,15	0,35	0
76	ALFA ROMEO	6C 2500 SS	1,55	1950-1952	>1101	S	0,15	0,15	0,20	0,05
77	ALFA ROMEO	6C 2500 S cabriolet Touring	1,40	1950-1952	>1101	GT	0,15	0,15	0,10	0
78	ALFA ROMEO	6C 3000 CM berlina Colli	1,60	1953-1957	>1101	SC	0,10	0,15	0,35	0
79	ALFA ROMEO	8C 2300 spider	1,70	1930-1934	>1101	SS	0,30	0,15	0,25	0
80	ALFA ROMEO	8C 2300	1,70	1930-1934	>1101	SS	0,30	0,15	0,25	0
81	ALFA ROMEO	8C 2300 Spider Touring (winner 1932)	1,80	1930-1934	>1101	SS	0,30	0,15	0,25	WOA
82	ALFA ROMEO	8C 2300 MM Spider Zagato (winner 1933)	1,80	1930-1934	>1101	SS	0,30	0,15	0,25	WOA

	MARCA MARQUE	MODELLO MODEL	COEFF. Multiplier	CALCULATION FACTOR						WINNER FACTOR
				PERIOD	CLASS	CAT.	PERIOD	CLASS	CAT.	
83	ALFA ROMEO	8C 2300 Monza	1,70	1930-1934	>1101	SS	0,30	0,15	0,25	0
84	ALFA ROMEO	8C 2300 spider Castagna	1,70	1930-1934	>1101	SS	0,30	0,15	0,25	0
85	ALFA ROMEO	8C 2600 Monza (winner 1934)	1,80	1930-1934	>1101	SS	0,30	0,15	0,25	WOA
86	ALFA ROMEO	8C 2600 Monza spider Brianza	1,70	1930-1934	>1101	SS	0,30	0,15	0,25	0
87	ALFA ROMEO	Tipo B 2900 "P3" (winner 1935)	1,80	1935-1940	>1101	SS	0,25	0,15	0,25	WOA
88	ALFA ROMEO	B 2900	1,65	1935-1940	>1101	SS	0,25	0,15	0,25	0
89	ALFA ROMEO	8C 2900 A (winner 1936 - 1937)	1,80	1935-1940	>1101	SS	0,25	0,15	0,25	WOA
90	ALFA ROMEO	8C 2900 B MM (winner 1938)	1,80	1935-1940	>1101	SS	0,25	0,15	0,25	WOA
91	ALFA ROMEO	8C 2900 B [senza compressore] Berlinetta (winner 1947)	1,80	1935-1940	>1101	SS	0,25	0,15	0,25	WOA
92	ALFA ROMEO	8C 2900 B MM spider Touring	1,65	1935-1940	>1101	SS	0,25	0,15	0,25	0
93	ALFA ROMEO	1900 e 1900 TI	1,35	1950-1952	>1101	T	0,15	0,15	0	0,05
94	ALFA ROMEO	1900 Super e 1900 Super TI	1,30	1953-1957	>1101	T	0,10	0,15	0	0,05
95	ALFA ROMEO	1900 M "Matta"	1,35	1950-1952	>1101	T	0,15	0,15	0	0,05
96	ALFA ROMEO	1900 C Gara	1,45	1950-1952	>1101	SP	0,15	0,15	0,15	0
97	ALFA ROMEO	1900 Sprint	1,40	1950-1952	>1101	GT	0,15	0,15	0,10	0
98	ALFA ROMEO	1900 Super Sprint	1,35	1953-1957	>1101	GT	0,10	0,15	0,10	0
99	ALFA ROMEO	1900 SSZ [Zagato]	1,40	1953-1957	>1101	SP	0,10	0,15	0,15	0
100	ALFA ROMEO	412 spider Touring	1,65	1950-1952	>1101	SC	0,15	0,15	0,35	0
101	ALFA ROMEO	412 spider Vignale	1,65	1950-1952	>1101	SC	0,15	0,15	0,35	0
102	ALFA ROMEO	Giulietta Sprint Bertone	1,35	1953-1957	>1101	GT	0,10	0,15	0,10	0
103	ALFA ROMEO	Giulietta Sprint Veloce Bertone	1,40	1953-1957	>1101	GT	0,10	0,15	0,10	0,05
104	ALFA ROMEO	Giulietta "Sebring"	1,45	1953-1957	>1101	S	0,10	0,15	0,20	0
105	ALFA ROMEO	Giulietta GTZ (Zagato)	1,40	1953-1957	>1101	SP	0,10	0,15	0,15	0
106	ALFA ROMEO	Giulietta spider monoposto Pinin Farina	1,45	1953-1957	>1101	S	0,10	0,15	0,20	0
107	ALFA ROMEO	Giulietta berlina	1,30	1953-1957	>1101	T	0,10	0,15	0	0,05
108	ALLARD	J2 Cadillac	1,50	1950-1952	>1101	S	0,15	0,15	0,20	0
109	ALPINE-RENAULT	A 106 MM	1,30	1953-1957	<750	SP	0,10	0	0,15	0,05
110	AMILCAR	1100	1,60	1930-1934	<1100	S	0,30	0,10	0,20	0
111	AMILCAR	CGSs siluro corsa	1,70	1927-1929	<1100	SS	0,35	0,10	0,25	0
112	AMILCAR	CGSs spider	1,65	1927-1929	<1100	S	0,35	0,10	0,20	0
113	AMP (Alfa Maserati Prete)	6C 2500 Sport	1,70	1947-1949	>1101	SC	0,20	0,15	0,35	0
114	ANSALDO	Tipo 4H	1,70	1927-1929	>1101	S	0,35	0,15	0,20	0
115	ANSALDO	Tipo 6B	1,70	1927-1929	>1101	S	0,35	0,15	0,20	0
116	ANSALDO	Tipo 6B IV serie	1,70	1927-1929	>1101	S	0,35	0,15	0,20	0
117	ARNOLT	Bristol *	1,45	1953-1957	>1101	S	0,10	0,15	0,20	0
118	ASTON MARTIN	Le Mans	1,65	1930-1934	>1101	S	0,30	0,15	0,20	0
119	ASTON MARTIN	Ulster	1,70	1935-1940	>1101	SS	0,25	0,15	0,25	0,05
120	ASTON MARTIN	2 Litre Speed Model	1,60	1935-1940	>1101	S	0,25	0,15	0,20	0
121	ASTON MARTIN	2 Litre Speed Model "Spa Special"	1,50	1950-1952	>1101	S	0,15	0,15	0,20	0
122	ASTON MARTIN	DB 2	1,45	1950-1952	>1101	GT	0,15	0,15	0,10	0,05
123	ASTON MARTIN	DB 2/4	1,35	1953-1957	>1101	GT	0,10	0,15	0,10	0
124	ASTON MARTIN	DB 3	1,60	1953-1957	>1101	SC	0,10	0,15	0,35	0
125	ASTON MARTIN	DB 3S	1,60	1953-1957	>1101	SC	0,10	0,15	0,35	0
126	AUSTIN	Seven Sports	1,60	1930-1934	<750	S	0,30	0,10	0,20	0
127	AUSTIN HEALEY	100/4	1,35	1953-1957	>1101	GT	0,10	0,15	0,10	0
128	AUSTIN HEALEY	100/6	1,35	1953-1957	>1101	GT	0,10	0,15	0,10	0
129	AUSTIN HEALEY	100 M	1,35	1953-1957	>1101	GT	0,10	0,15	0,10	0
130	AUSTIN HEALEY	100 S	1,50	1953-1957	>1101	S	0,10	0,15	0,20	0,05

	MARCA MARQUE	MODELLO MODEL	COEFF. Multiplier	CALCULATION FACTOR						WINNER FACTOR
				PERIOD	CLASS	CAT.	PERIOD	CLASS	CAT.	
131	AUTO AVIO COSTRUZIONI	815 spider Touring	1,65	1935-1940	>1101	SS	0,25	0,15	0,25	0
132	AUTOBLEU	Type Mille Miglia	1,30	1953-1957	<750	SC	0,10	0	0,20	0
133	AVALLE	FIAT 750 Sport	1,60	1947-1949	<750	SC	0,20	0	0,35	0,05
134	AVALLE	S.I.A.T.A. 500 FIAT sport spider	1,55	1947-1949	<750	SC	0,20	0	0,35	0
135	AVALLE	S.I.A.T.A. 750 S	1,60	1947-1949	<750	SC	0,20	0	0,35	0,05
136	AVALLE	FIAT 750 barchetta	1,55	1947-1949	<750	SC	0,20	0	0,35	0
137	AVALLE	FIAT 750 spider	1,55	1947-1949	<750	SC	0,20	0	0,35	0
138	AVALLE	Moretti 750 siluro	1,50	1950-1952	<750	SC	0,15	0	0,35	0
139	AVALLE	FIAT 1100/103 berlina Accossato	1,55	1953-1957	<1100	SC	0,10	0,10	0,35	0
140	BAISTROCCHI	Balestrieri FIAT 1100 Sport	1,65	1947-1949	<1100	SC	0,20	0,10	0,35	0
141	BALESTRIERI	Baistrocchi FIAT 1100 Sport	1,55	1953-1957	<1100	SC	0,10	0,10	0,35	0
142	BANDINI	750 S	1,45	1953-1957	<750	SC	0,10	0	0,35	0
143	BANDINI	750 S Crosley	1,45	1953-1957	<750	SC	0,10	0	0,35	0
144	BANDINI	FIAT 1100 Sport	1,65	1947-1949	<1100	SC	0,20	0,10	0,35	0
145	BASSO-LANCIA	"Aurora" barchetta motore Aprilia	1,70	1947-1949	>1101	SC	0,20	0,15	0,35	0
146	BENEDETTI	Ermini 1100 siluro	1,60	1950-1952	<1100	SC	0,15	0,10	0,35	0
147	BENEDETTI	Ermini 1100 Sport	1,60	1950-1952	<1100	SC	0,15	0,10	0,35	0
148	BENEDETTI	FIAT 1100 Siluro	1,65	1947-1949	<1100	SC	0,20	0,10	0,35	0
149	BENEDETTI	FIAT 750 barchetta	1,55	1947-1949	<750	SC	0,20	0	0,35	0
150	BENEDETTI	Giannini 750 S	1,60	1947-1949	<750	SC	0,20	0	0,35	0,05
151	BENEDETTI	Giannini 750 Spider	1,50	1950-1952	<750	SC	0,15	0	0,35	0
152	BENEDETTI	Lancia Aurelia B20 berlina	1,40	1950-1952	>1101	GT	0,15	0,15	0,10	0
153	BENTLEY	3.5 Litre *	1,65	1930-1934	>1101	S	0,30	0,15	0,20	0
154	BENTLEY	4.5 Litre Supercharged*	1,70	1930-1934	>1101	SS	0,30	0,15	0,25	0
155	BIANCHI	20	1,70	1927-1929	>1101	S	0,35	0,15	0,20	0
156	BIANCHI	20 Sport	1,70	1927-1929	>1101	S	0,35	0,15	0,20	0
157	BIANCHI	20 Sport Torpedo	1,70	1927-1929	>1101	S	0,35	0,15	0,20	0
158	BIANCHI	20 Torpedo	1,70	1927-1929	>1101	S	0,35	0,15	0,20	0
159	BIANCHI	S5	1,65	1930-1934	>1101	SP	0,30	0,15	0,15	0,05
160	BIANCHI	S5 1300 spider	1,60	1930-1934	>1101	SP	0,30	0,15	0,15	0
161	BIANCHI	S5 1300 torpedo	1,60	1930-1934	>1101	SP	0,30	0,15	0,15	0
162	BIONDETTI	Jaguar - Ferrari Special [telaio Ferrari 166, motore XK 120]	1,65	1950-1952	>1101	SC	0,15	0,15	0,35	0
163	BIONDETTI	Jaguar C-Type Special [telaio Ferrari 166, motore XKC]	1,65	1950-1952	>1101	SC	0,15	0,15	0,35	0
164	B.M.W.	328	1,60	1935-1940	>1101	S	0,25	0,15	0,20	0
165	B.M.W.	328 berlina Kamm	1,65	1935-1940	>1101	SS	0,25	0,15	0,25	0
166	B.M.W.	328 Berlina Touring (winner 1940)	1,80	1935-1940	>1101	SS	0,25	0,15	0,25	WOA
167	B.M.W.	328 spider aerodinamico MM	1,65	1935-1940	>1101	SS	0,25	0,15	0,25	0
168	B.M.W.	328 spider speciale	1,60	1947-1949	>1101	SS	0,20	0,15	0,25	0
169	B.M.W.	328 speciale	1,50	1950-1952	>1101	S	0,15	0,15	0,20	0
170	B.M.W.	502	1,30	1953-1957	>1101	T	0,10	0,15	0	0,05
171	B.M.W.	507	1,35	1953-1957	>1101	GT	0,10	0,15	0,10	0
172	B.M.W.	750	1,35	1950-1952	<750	S	0,15	0	0,20	0
173	B.M.W.	750 telaio FIAT 500 siluro	1,40	1947-1949	<750	S	0,20	0	0,20	0
174	B.M.W.	750 telaio FIAT 500 spider	1,40	1947-1949	<750	S	0,20	0	0,20	0
175	B.N.C.	1100 sport biposto*	1,70	1927-1929	<1100	SS	0,35	0,10	0,25	0
176	BONOMI	Giannini 750 siluro Motto	1,45	1953-1957	<750	SC	0,10	0	0,35	0
177	BORGWARD	Isabella TS	1,25	1953-1957	>1101	T	0,10	0,15	0	0

	MARCA MARQUE	MODELLO MODEL	COEFF. Multiplier	CALCULATION FACTOR						WINNER FACTOR
				PERIOD	CLASS	CAT.	PERIOD	CLASS	CAT.	
178	BRANCA	FIAT 750 S	1,45	1953-1957	<750	SC	0,10	0	0,35	0
179	BRANCA	Moretti 1100 S	1,55	1953-1957	<1100	SC	0,10	0,10	0,35	0
180	BRANCA	Moretti 750 S	1,45	1953-1957	<750	SC	0,10	0	0,35	0
181	BRANCA	Moretti 750 Sport maggiorata 1100	1,55	1953-1957	<1100	SC	0,10	0,10	0,35	0
182	BRANCA	Testadoro - Moretti 750 S	1,45	1953-1957	<750	SC	0,10	0	0,35	0
183	BRISTOL	400	1,45	1947-1949	>1101	GT	0,20	0,15	10,00	0
184	BRIXIA (GEROSA)	Gilco S.I.A.T.A. 750 spider	1,50	1950-1952	<750	SC	0,15	0	0,35	0
185	BUGATTI	GP 2 litri	1,70	1927-1929	>1101	S	0,35	0,15	0,20	0
186	BUGATTI	T 23 Brescia modifiée	1,70	1927-1929	>1101	S	0,35	0,15	0,20	0
187	BUGATTI	T 35	1,75	1927-1929	>1101	SS	0,35	0,15	0,25	0
188	BUGATTI	T 35 B	1,75	1927-1929	>1101	SS	0,35	0,15	0,25	0
189	BUGATTI	T 35 C	1,75	1927-1929	>1101	SS	0,35	0,15	0,25	0
190	BUGATTI	T 35 compressore	1,75	1927-1929	>1101	SS	0,35	0,15	0,25	0
191	BUGATTI	T 37	1,75	1927-1929	>1101	SS	0,35	0,15	0,25	0
192	BUGATTI	T 37 modificata 1100	1,70	1930-1934	>1101	SS	0,30	0,15	0,25	0
193	BUGATTI	T 38	1,70	1927-1929	>1101	S	0,35	0,15	0,20	0
194	BUGATTI	T 39	1,70	1927-1929	>1101	S	0,35	0,15	0,20	0
195	BUGATTI	T 40	1,75	1927-1929	>1101	S	0,35	0,15	0,20	0,05
196	BUGATTI	T 43	1,65	1930-1934	>1101	S	0,30	0,15	0,20	0
197	BUGATTI	T 43 GS	1,70	1927-1929	>1101	S	0,35	0,15	0,20	0
198	BUGATTI	T 50	1,65	1930-1934	>1101	S	0,30	0,15	0,20	0
199	BUGATTI	T 51	1,70	1930-1934	>1101	SS	0,30	0,15	0,25	0
200	BUGATTI	T 55	1,65	1930-1934	>1101	S	0,30	0,15	0,20	0
201	BUICK	Master Six	1,70	1927-1929	>1101	S	0,35	0,15	0,20	0
202	CAR-GEM CARNEVALLI	FIAT 508 C Sport	1,55	1935-1940	<1100	S	0,25	0,10	0,20	0
203	CAR-GEM CARNEVALLI	FIAT 1100 S	1,65	1947-1949	<1100	SC	0,20	0,10	0,35	0
204	CAR-GEM CARNEVALLI	TT 1100 siluro	1,60	1950-1952	<1100	SC	0,15	0,10	0,35	0
205	CEIRANO	S 150	1,70	1927-1929	>1101	S	0,35	0,15	0,20	0
206	CEIRANO	S 150 VVV	1,65	1930-1934	>1101	S	0,30	0,15	0,20	0
207	CFM	500 barchetta Bertone	1,55	1947-1949	<750	SC	0,20	0	0,35	0
208	CFM	Volkswagen 750 barchetta	1,55	1947-1949	<750	SC	0,20	0	0,35	0
209	CFM	Volkswagen 750 Siluro sport	1,35	1950-1952	<750	S	0,15	0	0,20	0
210	CHRYSLER	72 (tutte)	1,70	1927-1929	>1101	SP	0,35	0,15	0,15	0,05
211	CHRYSLER	75	1,70	1927-1929	>1101	SP	0,35	0,15	0,15	0,05
212	CHRYSLER	Saratoga 5300	1,30	1953-1957	>1101	T	0,10	0,15	0	0,05
213	CI-MA	FIAT 500 siluro Morelli carrozzato chiuso	1,40	1947-1949	<750	S	0,20	0	0,20	0
214	CI-MA	Turola - FIAT berlina	1,35	1950-1952	<750	S	0,15	0	0,20	0
215	CISITALIA	202 MM Savonuzzi berlina Vignale per Pinin Farina	1,50	1947-1949	<1100	S	0,20	0,10	0,20	0
216	CISITALIA	202 MM spider "razzo"	1,65	1947-1949	<1100	SC	0,20	0,10	0,35	0
217	CISITALIA	202 S MM berlina "cassone"	1,65	1947-1949	<1100	SC	0,20	0,10	0,35	0
218	CISITALIA	202 S MM berlina aerodinamica	1,65	1947-1949	<1100	SC	0,20	0,10	0,35	0
219	CISITALIA	202 S MM spider (Nuvolari)	1,70	1947-1949	<1100	SC	0,20	0,10	0,35	0,05
220	CISITALIA	202 SC berlina Pinin Farina	1,45	1947-1949	<1100	SP	0,20	0,10	0,15	0
221	CISITALIA	202 B berlina Pinin Farina	1,45	1950-1952	<1100	SP	0,15	0,10	0,15	0,05
222	CISITALIA	202 B berlina Vignale	1,40	1950-1952	<1100	SP	0,15	0,10	0,15	0
223	CISITALIA	202 cabriolet	1,35	1950-1952	<1100	GT	0,15	0,10	0,10	0
224	CISITALIA	202 cabriolet Pinin Farina	1,35	1950-1952	<1100	GT	0,15	0,10	0,10	0
225	CISITALIA	202 D 2800 cc	1,65	1950-1952	>1101	SC	0,15	0,15	0,35	0

	MARCA MARQUE	MODELLO MODEL	COEFF. Multiplier	CALCULATION FACTOR						WINNER FACTOR
				PERIOD	CLASS	CAT.	PERIOD	CLASS	CAT.	
226	CISITALIA	202 spider - hardtop	1,40	1950-1952	<1100	SP	0,15	0,10	0,15	0
227	CITROËN	C4	1,60	1930-1934	>1101	SP	0,30	0,15	0,15	0
228	CITROËN	modello non identificato	1,35	1947-1949	>1101	T	0,20	0,15	0	0
229	CITROËN	15	1,35	1947-1949	>1101	T	0,20	0,15	0	0
230	CITROËN	11 B	1,25	1953-1957	>1101	T	0,10	0,15	0	0
231	CITROËN	modello non identificato	1,25	1953-1957	>1101	T	0,10	0,15	0	0
232	CITROËN	15 Six	1,25	1953-1957	>1101	T	0,10	0,15	0	0
233	CITROËN	2 CV	1,10	1953-1957	<750	T	0,10	0	0	0
234	CITROEN	2 CV Carrozzeria Speciale	1,15	1953-1957	<750	T	0,10	0	0	0,05
235	CITROËN	DS 19	1,25	1953-1957	>1101	T	0,10	0,15	0	0
236	COMIRATO	FIAT 1100	1,60	1935-1940	<1100	SS	0,25	0,10	0,25	0
237	COMIRATO	FIAT 508 spider	1,60	1935-1940	<1100	SS	0,25	0,10	0,25	0
238	COMIRATO	GILCO FIAT 1100 siluro	1,70	1947-1949	<1100	SC	0,20	0,10	0,35	0,05
239	CONRERO	Alfa Romeo 1900 berlinetta Koren	1,60	1953-1957	>1101	SC	0,10	0,15	0,35	0
240	CONRERO	Alfa Romeo 1900 coupè Ghia	1,60	1953-1957	>1101	SC	0,10	0,15	0,35	0
241	COOPER	T25 Bristol	1,60	1953-1957	>1101	SC	0,10	0,15	0,35	0
242	COOPER	Jaguar T33	1,60	1953-1957	>1101	SC	0,10	0,15	0,35	0
243	COUSY	750 Sport *	1,30	1953-1957	<750	S	0,10	0	0,20	0
244	CRIVELLARI	500 A FIAT testa S.I.A.T.A.	1,55	1947-1949	<750	S	0,20	0	0,35	0
245	D.B.	Citroën Spider	1,50	1950-1952	>1101	S	0,15	0,15	0,20	0
246	D.B.	Panhard Berlinetta	1,25	1950-1952	<750	GT	0,15	0	0,10	0
247	D.B.	Panhard X86 berlinetta	1,30	1950-1952	<750	GT	0,15	0	0,10	0,05
248	D.B.	Panhard Tank	1,50	1953-1957	<750	SC	0,10	0	0,35	0,05
249	D.B.	Panhard 750 S	1,45	1953-1957	<750	SC	0,10	0	0,35	0
250	D.B.	Panhard 750 Berlinetta Zagato	1,45	1953-1957	<750	SC	0,10	0	0,35	0
251	D.B.	Panhard HBR	1,50	1953-1957	<750	SC	0,10	0	0,35	0,05
252	D.B.	Panhard HBR 5	1,30	1953-1957	<1100	GT	0,10	0,10	0,10	0
253	DEUTSCH-BONNET	Panhard HBR spider	1,30	1953-1957	<1100	GT	0,10	0,10	0,10	0
254	D.L.	Ardea 750 S Benelli - Ortolani	1,50	1950-1952	<750	SC	0,15	0	0,35	0
255	DAGRADA	FIAT 750 siluro	1,50	1950-1952	<750	SC	0,15	0	0,35	0
256	DAGRADA	FIAT 750 spider	1,50	1950-1952	<750	SC	0,15	0	0,35	0
257	DELAGE	D6 75 Sport	1,65	1935-1940	>1101	SS	0,25	0,15	0,25	0
258	DELAHAYE	135 CS	1,65	1935-1940	>1101	SS	0,25	0,15	0,25	0
259	DELAHAYE	135 MS	1,65	1935-1940	>1101	SS	0,25	0,15	0,25	0
260	DELAHAYE	135 MS spider	1,55	1950-1952	>1101	SS	0,15	0,15	0,25	0
261	DELAHAYE	145	1,70	1935-1940	>1101	SS	0,25	0,15	0,25	0,05
262	DELAHAYE	3500	1,35	1947-1949	>1101	T	0,20	0,15	0	0
263	DERBY	1100	1,65	1927-1929	<1100	S	0,35	0,10	0,20	0
264	DIATTO	26	1,70	1927-1929	>1101	S	0,35	0,15	0,20	0
265	DIATTO	30	1,70	1927-1929	>1101	S	0,35	0,15	0,20	0
266	DIATTO	35	1,70	1927-1929	>1101	S	0,35	0,15	0,20	0
267	DKW	Sonderklasse 3=6	1,25	1953-1957	<1100	T	0,10	0,10	0	0,05
268	E.F.A.C.	Stanguellini 750 S	1,45	1953-1957	<750	SC	0,10	0	0,35	0
269	EMANUELLI	FIAT 750 S	1,30	1953-1957	<750	S	0,10	0	0,20	0
270	ERMINI FIAT	1100 Sport Ala d'Oro	1,65	1947-1949	<1100	SC	0,20	0,10	0,35	0
271	ERMINI	1100 berlinetta Motto	1,60	1950-1952	<1100	SC	0,15	0,10	0,35	0
272	ERMINI	1100 Gilco spider Mariani	1,60	1950-1952	<1100	SC	0,15	0,10	0,35	0
273	ERMINI	1100 Sport	1,60	1950-1952	<1100	SC	0,15	0,10	0,35	0

	MARCA MARQUE	MODELLO MODEL	COEFF. Multiplier	CALCULATION FACTOR						WINNER FACTOR
				PERIOD	CLASS	CAT.	PERIOD	CLASS	CAT.	
274	ERMINI	Gilco 1100 Motto	1,60	1950-1952	<1100	SC	0,15	0,10	0,35	0
275	ERMINI	tipo 357 Sport 1500 Scaglietti	1,60	1953-1957	1101>	SC	0,10	0,15	0,35	0
276	EXCELSIOR	Ermini Gilco spider Colli	1,60	1950-1952	<1100	SC	0,15	0,10	0,35	0
277	F.L. (FIAT LAUREATI)	1100 spider	1,55	1953-1957	<1100	SC	0,10	0,10	0,35	0
278	F.L. (FIAT LAUREATI)	1100 Sport	1,55	1953-1957	<1100	SC	0,10	0,10	0,35	0
279	FACCIOLI	FIAT 750 S	1,50	1950-1952	<750	SC	0,15	0	0,35	0
280	FACCIOLI	Ortolani 750 S	1,35	1950-1952	<750	S	0,15	0	0,20	0
281	FANCIULLINI	250 Sport	1,30	1953-1957	<750	S	0,10	0	0,20	0
282	FERRARI	125 S spider	1,70	1947-1949	>1101	SC	0,20	0,15	0,35	0
283	FERRARI	166 S Coupé Allemano (winner 1948)	1,80	1947-1949	>1101	SC	0,20	0,15	0,35	WOA
284	FERRARI	166 S Spider [ex 125 S]	1,70	1947-1949	>1101	SC	0,20	0,15	0,35	0
285	FERRARI	166 Spider Corsa Ansaloni	1,70	1947-1949	>1101	SC	0,20	0,15	0,35	0
286	FERRARI	166 MM barchetta Touring	1,70	1947-1948	>1100	SC	0,20	0,15	0,35	0
287	FERRARI	166 Inter Spider Corsa Ansaloni	1,70	1947-1949	>1101	SC	0,20	0,15	0,35	0
288	FERRARI	166 MM spider Touring (winner 1949)	1,80	1947-1949	>1101	SC	0,20	0,15	0,35	WOA
289	FERRARI	166 Spider Corsa	1,70	1947-1949	>1101	SC	0,20	0,15	0,35	0
290	FERRARI	159/166 Spider Corsa Ansaloni	1,70	1947-1949	>1101	SC	0,20	0,15	0,35	0
291	FERRARI	166 Inter berlina Pinin Farina	1,65	1950-1952	>1101	SC	0,15	0,15	0,35	0
292	FERRARI	166 MM berlina Touring	1,65	1950-1952	>1101	SC	0,15	0,15	0,35	0
293	FERRARI	166 MM berlina Zagato	1,65	1950-1952	>1101	SC	0,15	0,15	0,35	0
294	FERRARI	166 MM berlina Touring Le Mans	1,65	1950-1952	>1101	SC	0,15	0,15	0,35	0
295	FERRARI	166 MM spider Vignale	1,65	1950-1952	>1101	SC	0,15	0,15	0,35	0
296	FERRARI	166 MM berlina Vignale	1,70	1950-1952	>1101	SC	0,15	0,15	0,35	0,05
297	FERRARI	166 Inter berlina Touring	1,45	1950-1952	>1101	SP	0,15	0,15	0,15	0
298	FERRARI	166 MM/53 berlina Touring Le Mans	1,60	1953-1957	>1101	SC	0,10	0,15	0,35	0
299	FERRARI	166 MM/53 spider Autodromo	1,60	1953-1957	>1101	SC	0,10	0,15	0,35	0
300	FERRARI	166 MM/53 spider Scaglietti	1,60	1953-1957	>1101	SC	0,10	0,15	0,35	0
301	FERRARI	166 MM/53 spider Vignale	1,60	1953-1957	>1101	SC	0,10	0,15	0,35	0
302	FERRARI	166 SC/195 S barchetta Fontana	1,65	1950-1952	>1101	SC	0,15	0,15	0,35	0
303	FERRARI	195 S berlina Touring (winner 1950)	1,80	1950-1952	>1101	SC	0,15	0,15	0,35	WOA
304	FERRARI	195 S barchetta Touring	1,65	1950-1952	>1101	SC	0,15	0,15	0,35	0
305	FERRARI	195 Inter coupé Motto	1,45	1950-1952	>1101	SP	0,15	0,15	0,15	0
306	FERRARI	212 Export berlina Motto	1,65	1950-1952	>1101	SC	0,15	0,15	0,35	0
307	FERRARI	212 Export berlina Vignale	1,65	1950-1952	>1101	SC	0,15	0,15	0,35	0
308	FERRARI	212 Export spider Motto	1,65	1950-1952	>1101	SC	0,15	0,15	0,35	0
309	FERRARI	195 Inter berlina Vignale	1,45	1950-1952	>1101	SP	0,15	0,15	0,15	0
310	FERRARI	212 Export berlina Touring	1,65	1950-1952	>1101	SC	0,15	0,15	0,35	0
311	FERRARI	212 Inter berlina Vignale	1,45	1950-1952	>1101	SP	0,15	0,15	0,15	0
312	FERRARI	220 Export spider Vignale	1,60	1953-1957	>1101	SC	0,10	0,15	0,35	0
313	FERRARI	212 Export spider Vignale	1,60	1953-1957	>1101	SC	0,10	0,15	0,35	0
314	FERRARI	212 Export barchetta Touring	1,60	1953-1957	>1101	SC	0,10	0,15	0,35	0
315	FERRARI	212 Inter coupé Vignale	1,40	1953-1957	>1101	SP	0,10	0,15	0,15	0
316	FERRARI	220 S	1,60	1953-1957	>1101	SC	0,10	0,15	0,35	0
317	FERRARI	225 S barchetta Touring	1,65	1950-1952	>1101	SC	0,15	0,15	0,35	0
318	FERRARI	225 S berlina Vignale	1,65	1950-1952	>1101	SC	0,15	0,15	0,35	0
319	FERRARI	225 S spider Vignale	1,65	1950-1952	>1101	SC	0,15	0,15	0,35	0
320	FERRARI	250 MM spider Vignale	1,60	1953-1957	>1101	SC	0,10	0,15	0,35	0
321	FERRARI	250 MM berlina Pinin Farina	1,60	1953-1957	>1101	SC	0,10	0,15	0,35	0

	MARCA MARQUE	MODELLO MODEL	COEFF. Multiplier	CALCULATION FACTOR						WINNER FACTOR
				PERIOD	CLASS	CAT.	PERIOD	CLASS	CAT.	
322	FERRARI	250 MM spider Morelli	1,60	1953-1957	>1101	SC	0,10	0,15	0,35	0
323	FERRARI	250 Monza spider Pinin Farina	1,60	1953-1957	>1101	SC	0,10	0,15	0,35	0
324	FERRARI	250 S berlinetta Vignale (winner 1952)	1,80	1950-1952	>1101	SC	0,15	0,15	0,35	WOA
325	FERRARI	250 GT Europa *	1,40	1953-1957	>1101	SP	0,10	0,15	0,15	0
326	FERRARI	250 GT LWB berlinetta Scaglietti	1,45	1953-1957	>1101	SP	0,10	0,15	0,15	0,05
327	FERRARI	250 GT berlinetta Pinin Farina	1,40	1953-1957	>1101	SP	0,10	0,15	0,15	0
328	FERRARI	250 GT coupé Boano	1,40	1953-1957	>1101	SP	0,10	0,15	0,15	0
329	FERRARI	250 GTZ coupé corsa Zagato	1,40	1953-1957	>1101	SP	0,10	0,15	0,15	0
330	FERRARI	250 GTZ berlinetta Zagato	1,40	1953-1957	>1101	SP	0,10	0,15	0,15	0
331	FERRARI	118 LM spider Scaglietti	1,65	1953-1957	>1101	SC	0,10	0,15	0,35	0,05
332	FERRARI	121 LM spider Scaglietti	1,60	1953-1957	>1101	SC	0,10	0,15	0,35	0
333	FERRARI	275 S barchetta Touring	1,65	1950-1952	>1101	SC	0,15	0,15	0,35	0
334	FERRARI	290 MM spider Scaglietti (winner 1956)	1,80	1953-1957	>1101	SC	0,10	0,15	0,35	WOA
335	FERRARI	315 S (winner 1957)	1,80	1953-1957	>1101	SC	0,10	0,15	0,35	WOA
336	FERRARI	335 S spider Scaglietti	1,60	1953-1957	>1101	SC	0,10	0,15	0,35	0
337	FERRARI	340 America barchetta Touring	1,65	1950-1952	>1101	SC	0,15	0,15	0,35	0
338	FERRARI	340 America berlinetta Vignale (winner 1951)	1,80	1950-1952	>1101	SC	0,15	0,15	0,35	WOA
339	FERRARI	340 America spider Vignale	1,65	1950-1952	>1101	SC	0,15	0,15	0,35	0
340	FERRARI	340 Mexico berlinetta Vignale	1,60	1953-1957	>1101	SC	0,10	0,15	0,35	0
341	FERRARI	340 MM barchetta Touring	1,60	1953-1957	>1101	SC	0,10	0,15	0,35	0
342	FERRARI	340 MM spider Vignale (winner 1953)	1,80	1953-1957	>1101	SC	0,10	0,15	0,35	WOA
343	FERRARI	375 MM berlinetta Pinin Farina	1,60	1953-1957	>1101	SC	0,10	0,15	0,35	0
344	FERRARI	375 MM spider Pinin Farina	1,60	1953-1957	>1101	SC	0,10	0,15	0,35	0
345	FERRARI	375 Plus spider Pinin Farina	1,60	1953-1957	>1101	SC	0,10	0,15	0,35	0
346	FERRARI	410 SA *	1,60	1953-1957	>1101	SC	0,10	0,15	0,35	0
347	FERRARI	500 Mondial spider Scaglietti	1,65	1953-1957	>1101	SC	0,10	0,15	0,35	0,05
348	FERRARI	500 Mondial berlinetta Pinin Farina	1,60	1953-1957	>1101	SC	0,10	0,15	0,35	0
349	FERRARI	500 Mondial spider Pinin Farina	1,60	1953-1957	>1101	SC	0,10	0,15	0,35	0
350	FERRARI	500 TRC spider Scaglietti	1,65	1953-1957	>1101	SC	0,10	0,15	0,35	0,05
351	FERRARI	500 TR spider Scaglietti	1,60	1953-1957	>1101	SC	0,10	0,15	0,35	0
352	FERRARI	750 Monza spider Scaglietti	1,60	1953-1957	>1101	SC	0,10	0,15	0,35	0
353	FERRARI	860 Monza spider Scaglietti	1,60	1953-1957	>1101	SC	0,10	0,15	0,35	0
354	FERRERO	FIAT 1100 S	1,45	1950-1952	<1100	S	0,15	0,10	0,20	0
355	FERRY	F750 Renault	1,30	1953-1957	<750	S	0,10	0	0,20	0
356	FIAT	501 S	1,70	1927-1929	≥1101	S	0,35	0,15	0,20	0
357	FIAT	501 testa Silvani spider speciale	1,70	1927-1929	≥1101	S	0,35	0,15	0,20	0
358	FIAT	509 S	1,70	1927-1929	<1100	S	0,35	0,10	0,20	0,05
359	FIAT	509 S guida interna	1,60	1927-1929	<1100	SP	0,35	0,10	0,15	0
360	FIAT	509 S bateau	1,65	1927-1929	<1100	S	0,35	0,10	0,20	0
361	FIAT	509 SM	1,60	1930-1934	<1100	S	0,30	0,10	0,20	0
362	FIAT	508 "Balilla" 3 marce (tutte/all)	1,55	1930-1934	<1100	SP	0,30	0,10	0,15	0
363	FIAT	508 S "Balilla"berlinetta aerodinamica	1,55	1930-1934	<1100	SP	0,30	0,10	0,15	0
364	FIAT	508 S "Balilla" Coppa d'Oro	1,60	1930-1934	<1100	SP	0,30	0,10	0,15	0,05
365	FIAT	508 S "Balilla" Mille Miglia	1,60	1930-1934	<1100	SP	0,30	0,10	0,15	0,05
366	FIAT	508 CS Sport "Balilla" compressore	1,55	1935-1940	<1100	S	0,25	0,10	0,20	0
367	FIAT	508 CS S "Balilla" berlinetta Ala d'Oro	1,55	1935-1940	<1100	S	0,25	0,10	0,20	0
368	FIAT	508 CS spider Touring	1,55	1935-1940	<1100	S	0,25	0,10	0,20	0
369	FIAT	508 CS MM berlinetta	1,55	1935-1940	<1100	S	0,25	0,10	0,20	0

	MARCA MARQUE	MODELLO MODEL	COEFF. Multiplier	CALCULATION FACTOR						WINNER FACTOR
				PERIOD	CLASS	CAT.	PERIOD	CLASS	CAT.	
370	FIAT	508 C Balilla 1100 (tutte/all)	1,50	1935-1940	<1100	SP	0,25	0,10	0,15	0
371	FIAT	508 L Balilla 1100 (tutte/all)	1,50	1935-1940	<1100	SP	0,25	0,10	0,15	0
372	FIAT	508 Sport "Balilla" gasogeno	1,55	1935-1940	<1100	SP	0,25	0,10	0,15	0,05
373	FIAT	1100 [508 C] Sport	1,55	1935-1940	<1100	S	0,25	0,10	0,20	0
374	FIAT	1100 [508 C] berlina con compressore	1,50	1935-1940	<1100	SP	0,25	0,10	0,15	0
375	FIAT	1100 [508 C] MM berlina	1,60	1935-1940	<1100	SS	0,25	0,10	0,25	0
376	FIAT	1100 [508 C] MM berlina Savio	1,60	1935-1940	<1100	SS	0,25	0,10	0,25	0
377	FIAT	1100 [508 C] barchetta	1,60	1935-1940	<1100	SS	0,25	0,10	0,25	0
378	FIAT	1100 [508 C] spider	1,60	1935-1940	<1100	SS	0,25	0,10	0,25	0
379	FIAT	1100 [508 C] berlina aerodinamica	1,60	1935-1940	<1100	SS	0,25	0,10	0,25	0
380	FIAT	514	1,60	1930-1934	>1101	SP	0,30	0,15	0,15	0
381	FIAT	514 CA	1,60	1930-1934	>1101	SP	0,30	0,15	0,15	0
382	FIAT	514 CA spider sport	1,60	1930-1934	>1101	SP	0,30	0,15	0,15	0
383	FIAT	514 MM	1,70	1930-1934	>1101	S	0,30	0,15	0,15	0,05
384	FIAT	514 S	1,65	1930-1934	>1101	SP	0,30	0,15	0,15	0,05
385	FIAT	519 S	1,75	1927-1929	>1101	S	0,35	0,15	0,20	0,05
386	FIAT	520	1,65	1927-1929	>1101	SP	0,35	0,15	0,15	0
387	FIAT	520 versioni corsa	1,70	1927-1929	>1101	S	0,35	0,15	0,20	0
388	FIAT	522	1,60	1930-1934	>1101	SP	0,30	0,15	0,15	0
389	FIAT	525 S berlina	1,45	1930-1934	>1101	T	0,30	0,15	0	0
390	FIAT	525 S	1,60	1930-1934	>1101	SP	0,30	0,15	0,15	0
391	FIAT	525 SS	1,65	1930-1934	>1101	S	0,30	0,15	0,20	0
392	FIAT	527 Ardita	1,40	1935-1940	>1101	T	0,25	0,15	0	0
393	FIAT	2800 *	1,40	1935-1940	>1101	T	0,25	0,15	0	0
394	FIAT	1100 berlina	1,30	1947-1949	<1100	T	0,20	0,10	0	0
395	FIAT	1100 S MM (gobbone)	1,50	1947-1949	<1100	S	0,20	0,10	0,20	0
396	FIAT	1100 S	1,50	1947-1949	<1100	S	0,20	0,10	0,20	0
397	FIAT	1100 S barchetta	1,65	1947-1949	<1100	SC	0,20	0,10	0,35	0
398	FIAT	1100 S	1,45	1950-1952	<1100	S	0,15	0,10	0,20	0
399	FIAT	1100 S barchetta	1,60	1950-1952	<1100	SC	0,15	0,10	0,35	0
400	FIAT	1100 hardtop Ala d'Oro	1,50	1947-1949	<1100	S	0,20	0,10	0,20	0
401	FIAT	1100 Metano	1,30	1947-1949	<1100	T	0,20	0,10	0	0
402	FIAT	1100 S berlina "Gobbone"	1,55	1947-1949	<1100	S	0,20	0,10	0,20	0,05
403	FIAT	1100 B spider Monviso	1,30	1947-1949	<1100	T	0,20	0,10	0	0
404	FIAT	1100 B berlina	1,30	1947-1949	<1100	T	0,15	0,10	0	0,05
405	FIAT	1100 siluro	1,65	1947-1949	<1100	SC	0,20	0,10	0,35	0
406	FIAT	1100 spider Ala d'Oro	1,50	1947-1949	<1100	S	0,20	0,10	0,20	0
407	FIAT	1100 barchetta	1,65	1947-1949	<1100	SC	0,20	0,10	0,35	0
408	FIAT	1100 coupé	1,50	1947-1949	<1100	S	0,20	0,10	0,20	0
409	FIAT	1100 coupé Ghia "Supergioiello"	1,50	1947-1949	<1100	S	0,20	0,10	0,20	0
410	FIAT	1100 S coupé Allemano	1,50	1947-1949	<1100	S	0,20	0,10	0,20	0
411	FIAT	1100 E berlina	1,30	1950-1952	<1100	T	0,15	0,10	0	0,05
412	FIAT	1100 ES berlina Pinin Farina	1,35	1950-1952	<1100	GT	0,15	0,10	0,10	0
413	FIAT	1100 S berlina Bertone	1,40	1950-1952	>1101	GT	0,15	0,15	0,10	0
414	FIAT	1100 S Rocco Motto	1,45	1950-1952	<1100	S	0,15	0,10	0,20	0
415	FIAT	1100 S siluro	1,60	1950-1952	<1100	SS	0,15	0,10	0,35	0
416	FIAT	1100/103 berlina	1,25	1953-1957	<1100	T	0,10	0,10	0	0,05
417	FIAT	1100/103 TV berlina	1,25	1953-1957	<1100	T	0,10	0,10	0	0,05

	MARCA MARQUE	MODELLO MODEL	COEFF. Multiplier	CALCULATION FACTOR						WINNER FACTOR
				PERIOD	CLASS	CAT.	PERIOD	CLASS	CAT.	
418	FIAT	1100/103 TV coupé Pininfarina	1,35	1953-1957	<1100	GT	0,10	0,10	0,10	0,05
419	FIAT	1100/103 TV spider	1,30	1953-1957	<1100	GT	0,10	0,10	0,10	0
420	FIAT	1400 berlina	1,35	1950-1952	>1101	T	0,15	0,15	0	0,05
421	FIAT	1400 A Diesel	1,25	1953-1957	>1101	T	0,10	0,15	0	0
422	FIAT	1500 Berlina (anteguerra)	1,45	1935-1940	>1101	T	0,25	0,15	0	0,05
423	FIAT	1500 Berlina (dopoguerra)	1,35	1947-1949	>1101	T	0,20	0,15	0	0
424	FIAT	1500 berlinetta Viotti	1,50	1935-1940	>1101	GT	0,25	0,15	0,10	0
425	FIAT	1500 cabriolet Viotti	1,50	1935-1940	>1101	GT	0,25	0,15	0,10	0
426	FIAT	1500 spider	1,50	1935-1940	>1101	GT	0,25	0,15	0,10	0
427	FIAT	1500 sport	1,55	1947-1949	>1101	S	0,20	0,15	0,20	0
428	FIAT	500	1,25	1950-1952	<750	GT	0,15	0	0,10	0
429	FIAT	500 A "Topolino"	1,30	1935-1940	<750	T	0,25	0	0	0,05
430	FIAT	500 A testa S.I.A.T.A.	1,45	1935-1940	<750	S	0,25	0	0,20	0
431	FIAT	500 testa S.I.A.T.A.	1,45	1935-1940	<750	S	0,25	0	0,20	0
432	FIAT	500 siluro	1,50	1935-1940	<750	SS	0,25	0	0,25	0
433	FIAT	500 spider	1,50	1935-1940	<750	SS	0,25	0	0,25	0
434	FIAT	500 sport	1,40	1947-1949	<750	S	0,20	0	0,20	0
435	FIAT	500 barchetta	1,40	1947-1949	<750	S	0,20	0	0,20	0
436	FIAT	500 B "Topolino"	1,25	1947-1949	<750	T	0,20	0	0	0,05
437	FIAT	500 C "Belvedere"	1,15	1950-1952	<750	T	0,15	0	0	0
438	FIAT	500 C "Topolino"	1,20	1950-1952	<750	T	0,15	0	0	0,05
439	FIAT	500 C "Topolino" testa Superba	1,25	1950-1952	<750	GT	0,15	0	0,10	0
440	FIAT	1900 berlina	1,25	1953-1957	>1101	T	0,10	0,15	0	0
441	FIAT	600	1,15	1953-1957	<750	T	0,10	0	0	0,05
442	FIAT	600 coupé	1,20	1953-1957	<750	GT	0,10	0	0,10	0
443	FIAT	SIATA 750 Sport "Fenocchio"	1,40	1947-1949	<750	S	0,20	0	0,20	0
444	FIAT	750 sport	1,40	1947-1949	<750	S	0,20	0	0,20	0
445	FIAT	750 Sport	1,30	1953-1957	<750	S	0,10	0	0,20	0
446	FIAT	8V berlinetta	1,45	1950-1952	>1101	SP	0,15	0,15	0,15	0
447	FIAT	8V berlinetta Vignale	1,40	1953-1957	>1101	SP	0,10	0,15	0,15	0
448	FIAT	8V berlinetta Zagato	1,45	1953-1957	>1101	SP	0,10	0,15	0,15	0,05
449	FIAT	Campagnola	1,30	1950-1952	>1101	T	0,15	0,15	0	0
450	FIAT-SIMCA	1100 [508 C] barchetta Grolleau-Deho	1,60	1935-1940	<1100	SS	0,25	0,10	0,25	0
451	FICAI	1100 S FIAT coupé Allemano	1,45	1950-1952	<1100	S	0,15	0,10	0,20	0
452	FICAI	1100 S FIAT coupé Allemano	1,50	1947-1949	<1100	S	0,20	0,10	0,20	0
453	FICAI	Nardi 750 Norton bicilindrico	1,40	1953-1957	<1100	S	0,10	0,10	0,20	0
454	FONA	FIAT 1100 3 carburatori spider	1,60	1950-1952	<1100	SC	0,15	0,10	0,35	0
455	FONA	FIAT 1100 S	1,60	1950-1952	<1100	SC	0,15	0,10	0,35	0
456	FONA	FIAT 1100 S berlinetta	1,65	1947-1949	<1100	SC	0,20	0,10	0,35	0
457	FONA	FIAT 1100 S siluro	1,60	1950-1952	<1100	SC	0,15	0,10	0,35	0
458	FONA	FIAT 1100 siluro	1,65	1947-1949	<1100	SC	0,20	0,10	0,35	0
459	FONTANELLA	FIAT 500 siluro	1,40	1947-1949	<750	S	0,20	0	0,20	0
460	FORD	Taurus	1,30	1953-1957	>1101	T	0,10	0,15	0	0,05
461	FORD [GB]	Zephyr	1,25	1953-1957	>1101	T	0,10	0,15	0	0
462	FORD [USA]	A	1,60	1930-1934	>1101	SP	0,30	0,15	0,15	0
463	FORD [USA]	B 8V	1,60	1930-1934	>1101	SP	0,30	0,15	0,15	0
464	FORD [USA]	Thunderbird	1,35	1953-1957	>1101	GT	0,10	0,15	0,10	0
465	FRAZER NASH-B.M.W.	328	1,65	1935-1940	>1101	S	0,25	0,15	0,20	0,05

	MARCA MARQUE	MODELLO MODEL	COEFF. Multiplier	CALCULATION FACTOR						WINNER FACTOR
				PERIOD	CLASS	CAT.	PERIOD	CLASS	CAT.	
466	FRAZER - NASH	High Speed	1,55	1947-1949	>1101	S	0,20	0,15	0,20	0
467	FRAZER - NASH	Le Mans coupé	1,45	1953-1957	>1101	S	0,10	0,15	0,20	0
468	FRAZER - NASH	Le Mans Replica	1,50	1950-1952	>1101	S	0,15	0,15	0,20	0
469	FRAZER - NASH	Mille Miglia	1,55	1947-1949	>1101	S	0,20	0,15	0,20	0
470	FRAZER - NASH	Fast Tourer Bristol	1,55	1947-1949	>1101	S	0,20	0,15	0,20	0
471	FREDIANI	Lancia Ardea 750 Mariani	1,45	1953-1957	<750	SC	0,10	0	0,35	0
472	FURIA	DKW telaio FIAT 1100	1,55	1947-1949	>1101	S	0,20	0,15	0,20	0
473	GARAGE VITTORIA	FIAT 1100 barchetta Pietronboni	1,70	1947-1949	>1101	SC	0,20	0,15	0,35	0
474	GARAVINI	FIAT 1500 spider	1,75	1935-1940	>1101	SC	0,25	0,15	0,35	0
475	GEROSA	FIAT 750	1,50	1950-1952	<750	SC	0,15	0	0,35	0
476	GEROSA	Gilco 750 S.I.A.T.A. berlina	1,35	1950-1952	<750	S	0,15	0	0,20	0
477	GIANNINI	FIAT 500 berlina Scuderia Parioli	1,50	1935-1940	<750	SS	0,25	0	0,25	0
478	GIANNINI	750 S berlina	1,55	1947-1949	<750	SC	0,20	0	0,35	0
479	GIANNINI	750 S barchetta	1,55	1947-1949	<750	SC	0,20	0	0,35	0
480	GIANNINI	750 S barchetta	1,50	1950-1952	<750	SC	0,15	0	0,35	0
481	GIANNINI	750 S barchetta	1,45	1953-1957	<750	SC	0,10	0	0,35	0
482	GIANNINI	750 S siluro	1,55	1947-1949	<750	SC	0,20	0	0,35	0
483	GIANNINI	750 S siluro	1,50	1950-1952	<750	SC	0,15	0	0,35	0
484	GIAUR	750 berlina	1,50	1950-1952	<750	SC	0,15	0	0,35	0
485	GIAUR	750 S	1,50	1950-1952	<750	SC	0,15	0	0,35	0
486	GIAUR	750 S	1,45	1953-1957	<750	SC	0,10	0	0,35	0
487	GIAUR	"San Remo" 750 berlina Motto	1,45	1953-1957	<750	SC	0,10	0	0,35	0
488	GIAUR	750 spider Campana	1,45	1953-1957	<750	SC	0,10	0	0,35	0
489	GILCO	FIAT 1100 Siluro Mariani	1,65	1947-1949	<1100	SC	0,20	0,10	0,35	0
490	GILCO	FIAT 1100 barchetta Fontana	1,60	1950-1952	<1100	SC	0,15	0,10	0,35	0
491	GILCO	FIAT 1100 Sport	1,60	1950-1952	<1100	SC	0,15	0,10	0,35	0
492	GILCO	S.I.A.T.A. 750 Siluro	1,50	1950-1952	<750	SC	0,15	0	0,35	0
493	GILCO	FIAT 1100 spider Barbero	1,55	1953-1957	<1100	SC	0,10	0,10	0,35	0
494	GIUSTI	Testadoro "Daniela" siluro Zagato	1,55	1947-1949	<750	SC	0,20	0	0,35	0
495	GOLIATH	GP 700	1,10	1953-1957	<750	T	0,10	0	0	0
496	GORDINI	Simca 1100 Sport	1,65	1947-1949	<1100	SC	0,20	0,10	0,35	0
497	GORDINI	T15 S 1500	1,60	1953-1957	>1101	SC	0,10	0,15	0,35	0
498	GORDINI	T20 S 2000	1,60	1953-1957	>1101	SC	0,10	0,15	0,35	0
499	GORDINI	T24 S 3000	1,60	1953-1957	>1101	SC	0,10	0,15	0,35	0
500	GORDINI	T8 S 1100	1,60	1953-1957	>1101	SC	0,10	0,15	0,35	0
501	GPG	Stoewer 2000 barchetta Colli	1,70	1947-1949	>1101	SC	0,20	0,15	0,35	0
502	GRAHAM-PAIGE	modello non identificato	1,60	1930-1934	>1101	SP	0,30	0,15	0,15	0
503	GUARDIANI	FIAT 500 spider	1,55	1947-1949	<750	SC	0,20	0	0,35	0
504	GUITIN	1100 barchetta	1,55	1953-1957	<1100	SC	0,10	0,10	0,35	0
505	HEALEY	2400 Elliott	1,40	1947-1949	>1101	T	0,20	0,15	0	0,05
506	HEALEY	Duncan Drone	1,55	1947-1949	>1101	S	0,20	0,15	0,20	0
507	HEALEY	Beutler	1,50	1947-1949	>1101	SP	0,20	0,15	0,15	0
508	HEALEY	2400 Westland	1,55	1947-1949	>1101	SP	0,20	0,15	0,15	0,05
509	HEALEY	2400 Silverstone (D-Type)	1,55	1947-1949	>1101	S	0,20	0,15	0,20	0
510	HEALEY	2400 Silverstone (E-Type)	1,50	1950-1952	>1101	S	0,15	0,15	0,20	0
511	HISPANO-SUIZA	HB 6	1,65	1930-1934	>1101	S	0,30	0,15	0,20	0
512	HOTCHKISS	3000 *	1,55	1947-1949	>1101	S	0,20	0,15	0,20	0
513	HW (POI HWM)	Alta 2000 Sport	1,65	1950-1952	>1101	SC	0,15	0,15	0,35	0

	MARCA MARQUE	MODELLO MODEL	COEFF. Multiplier	CALCULATION FACTOR						WINNER FACTOR
				PERIOD	CLASS	CAT.	PERIOD	CLASS	CAT.	
514	HWM	Jaguar S 3400 cm3	1,60	1953-1957	>1101	SC	0,10	0,15	0,35	0
515	HWM	Jaguar S 3800 cm3	1,60	1953-1957	>1101	SC	0,10	0,15	0,35	0
516	ICOT	FIAT 1100	1,50	1947-1949	<1100	S	0,20	0,10	0,20	0
517	ISO	Isetta 236 cc	1,15	1953-1957	<750	T	0,10	0	0	0,05
518	ISOTTA FRASCHINI	8A SS torpedo Sala	1,75	1927-1929	>1101	S	0,35	0,15	0,20	0,05
519	ITALA	61	1,70	1927-1929	>1101	S	0,35	0,15	0,20	0
520	ITALA	61 berlina aerodinamica	1,70	1927-1929	>1101	S	0,35	0,15	0,20	0
521	ITALA	65	1,65	1930-1934	>1101	S	0,30	0,15	0,20	0
522	ITALA	75V spider	1,65	1930-1934	>1101	S	0,30	0,15	0,20	0
523	ITALA	speciale Diesel	1,60	1930-1934	>1101	SP	0,30	0,15	0,15	0
524	ITALA	speciale gasogeno	1,55	1935-1940	>1101	SP	0,25	0,15	0,15	0
525	JAGUAR	C - Type	1,65	1950-1952	>1101	SC	0,15	0,15	0,35	0
526	JAGUAR	D - Type	1,60	1953-1957	>1101	SC	0,10	0,15	0,35	0
527	JAGUAR	Mark VII	1,30	1950-1952	>1101	T	0,15	0,15	0	0
528	JAGUAR	XK 120 OTS roadster Lightweight	1,50	1947-1949	>1101	SP	0,20	0,15	0,15	0
529	JAGUAR	XK 120 OTS roadster	1,40	1950-1952	>1101	GT	0,15	0,15	0,10	0
530	JAGUAR	XK 120 coupé	1,40	1950-1952	>1101	GT	0,15	0,15	0,10	0
531	JAGUAR	Xk 140 OTS roadster	1,40	1953-1957	>1101	GT	0,10	0,15	0,10	0,05
532	JORDAN	Blue Boy	1,70	1927-1929	>1101	S	0,35	0,15	0,20	0
533	JORDAN	JE "Blueboy" tourer	1,65	1930-1934	>1101	S	0,30	0,15	0,20	0
534	KIEFT	Turner *	1,60	1953-1957	>1101	SC	0,10	0,15	0,35	0
535	KURTIS CHRYSLER	500 X "Caballo de Hierro" 6.420 cm3	1,60	1953-1957	>1101	SC	0,10	0,15	0,35	0
536	LA SALLE	Series 303 torpedo	1,75	1927-1929	>1101	S	0,35	0,15	0,20	0,05
537	LAGONDA	M45 Rapide *	1,65	1935-1940	>1101	SS	0,25	0,15	0,25	0
538	LANCIA	Lambda berlina	1,50	1927-1929	>1101	T	0,35	0,15	0	0
539	LANCIA	Lambda Tipo 214 (corto)	1,75	1927-1929	>1101	SS	0,35	0,15	0,25	0
540	LANCIA	Lambda Tipo 216 e 217 (lungo)	1,50	1927-1929	>1101	T	0,35	0,15	0	0
541	LANCIA	Lambda Tipo 218 e 219 (corto)	1,75	1927-1929	>1101	SS	0,35	0,15	0,25	0
542	LANCIA	Lambda Tipo 221 e 223 (corto)	1,75	1927-1929	>1101	SS	0,35	0,15	0,25	0
543	LANCIA	Lambda Tipo 222 e 224 (lungo)	1,50	1927-1929	>1101	T	0,35	0,15	0	0
544	LANCIA	Lambda torpedo Tipo 218 Corsa	1,80	1927-1929	>1101	SS	0,35	0,15	0,25	0,05
545	LANCIA	Lambda spider Tipo 221 Casaro	1,80	1927-1929	>1101	SS	0,35	0,15	0,25	0,05
546	LANCIA	Lambda spider corsa	1,75	1927-1929	>1101	SS	0,35	0,15	0,25	0
547	LANCIA	Lambda speciale (motore Dilambda)	1,80	1930-1934	>1101	SS	0,35	0,15	0,25	0,05
548	LANCIA	Dilambda	1,70	1930-1934	>1101	S	0,30	0,15	0,20	0,05
549	LANCIA	Artena	1,65	1930-1934	>1101	S	0,30	0,15	0,20	0
550	LANCIA	Astura	1,60	1930-1934	>1101	SP	0,30	0,15	0,15	0
551	LANCIA	Astura berlina Lotti	1,45	1930-1934	>1101	T	0,30	0,15	0	0
552	LANCIA	Astura spider corsa	1,65	1935-1940	>1101	SS	0,25	0,15	0,25	0
553	LANCIA	Augusta	1,55	1935-1940	>1101	SP	0,25	0,15	0,15	0
554	LANCIA	Augusta berlina	1,55	1935-1940	>1101	SP	0,25	0,15	0,15	0
555	LANCIA	Augusta berlinetta aerodinamica	1,55	1935-1940	>1101	SP	0,25	0,15	0,15	0
556	LANCIA	Augusta Belna Cabriolet	1,55	1935-1940	>1101	SP	0,25	0,15	0,15	0
557	LANCIA	Augusta cabriolet	1,55	1935-1940	>1101	SP	0,25	0,15	0,15	0
558	LANCIA	Aprilia spider Touring "Ala spessa"	1,60	1935-1940	>1101	S	0,25	0,15	0,20	0
559	LANCIA	Aprilia Spider Zagato	1,70	1935-1940	>1101	SS	0,25	0,15	0,25	0,05
560	LANCIA	Aprilia berlinetta aerodinamica Pinin Farina	1,60	1935-1940	>1101	S	0,25	0,15	0,20	0
561	LANCIA	Aprilia berlinetta aerodinamica Boneschi	1,60	1935-1940	>1101	S	0,25	0,15	0,20	0

	MARCA MARQUE	MODELLO MODEL	COEFF. Multiplier	CALCULATION FACTOR						WINNER FACTOR
				PERIOD	CLASS	CAT.	PERIOD	CLASS	CAT.	
562	LANCIA	Aprilia Spider	1,65	1935-1940	>1101	S	0,25	0,15	0,20	0,05
563	LANCIA	Aprilia spider Colli	1,60	1935-1940	>1101	S	0,25	0,15	0,20	0
564	LANCIA	Aprilia spider Colli hardtop	1,60	1935-1940	>1101	S	0,25	0,15	0,20	0
565	LANCIA	Aprilia berlina 1350	1,55	1935-1940	>1101	SP	0,25	0,15	0,15	0
566	LANCIA	Aprilia berlina 1500	1,40	1947-1949	>1101	T	0,20	0,15	0	0,05
567	LANCIA	Aprilia Sport	1,75	1947-1949	>1101	SC	0,20	0,15	0,35	0,05
568	LANCIA	Aprilia spider	1,70	1947-1949	>1101	SC	0,20	0,15	0,35	0
569	LANCIA	Ardea berlina 1^ e 2^ serie	1,40	1935-1940	<1100	T	0,25	0,10	0	0,05
570	LANCIA	Ardea berlina 3^ e 4^ serie	1,35	1947-1949	<1100	T	0,20	0,10	0	0,05
571	LANCIA	Ardea 750 S	1,45	1953-1957	<750	SC	0,10	0	0,35	0
572	LANCIA	Aurelia B12 berlina	1,25	1953-1957	>1101	T	0,10	0,15	0	0
573	LANCIA	Aurelia B21 berlina	1,35	1950-1952	>1101	T	0,15	0,15	0	0,05
574	LANCIA	Aurelia B22 berlina	1,25	1953-1957	>1101	T	0,10	0,15	0	0
575	LANCIA	Aurelia B20 GT 2000 berlina Pinin Farina	1,45	1950-1952	>1101	GT	0,15	0,15	0,10	0,05
576	LANCIA	Aurelia B20 GT 2500 berlina Pinin Farina	1,40	1953-1957	>1101	GT	0,10	0,15	0,10	0,05
577	LANCIA	Aurelia B24 spider "America" Pinin Farina	1,35	1953-1957	>1101	GT	0,10	0,15	0,10	0
578	LANCIA	Aurelia B50 GT coupé Vignale	1,40	1950-1952	>1101	GT	0,15	0,15	0,10	0
579	LANCIA	D20 berlina Pinin Farina	1,60	1953-1957	>1101	SC	0,10	0,15	0,35	0
580	LANCIA	D24 Spider (winner 1954)	1,80	1953-1957	>1101	SC	0,10	0,15	0,35	WOA
581	LANCIA	Appia	1,20	1953-1957	<1100	T	0,10	0,10	0	0
582	LANCIA	Appia coupé Motto	1,30	1953-1957	<1100	GT	0,10	0,10	0,10	0
583	LANCIA	Appia GTZ	1,35	1953-1957	<1100	GT	0,10	0,10	0,10	0,05
584	LEONE	FIAT 1100 Sport	1,65	1947-1949	<1100	SC	0,20	0,10	0,35	0
585	LEONE	Lancia - FIAT 1100 barchetta	1,70	1935-1940	<1100	SC	0,25	0,10	0,35	0
586	LEONE	Savonuzzi 1100 FIAT barchetta	1,65	1947-1949	<1100	SC	0,20	0,10	0,35	0
587	LEONE	Savonuzzi 1100 FIAT siluro	1,60	1950-1952	<1100	SC	0,15	0,10	0,35	0
588	LINCOLN	Capri	1,45	1953-1957	>1101	S	0,10	0,15	0,20	0
589	LOMBARD	AL3 *	1,65	1927-1929	<1100	S	0,35	0,10	0,20	0
590	LORRAINE-DIETRICH	B/3/6	1,70	1927-1929	>1101	S	0,35	0,15	0,20	0
591	LOTUS	Eleven Climax	1,55	1953-1957	<1100	SC	0,10	0,10	0,35	0
592	LOTUS	Lotus Mk IX Climax *	1,55	1953-1957	<1100	SC	0,10	0,10	0,35	0
593	MAESTRI-BARTOLINI	Giannini 750 spider	1,50	1950-1952	<750	SC	0,15	0	0,35	0
594	MARDAL	750 Giannini - Gilco Fontana	1,50	1950-1952	<750	SC	0,15	0	0,35	0
595	MARINO (BRANDOLI)	FIAT 1100 Sport	1,55	1953-1957	<1100	SC	0,10	0,10	0,35	0
596	MARINO (BRANDOLI)	FIAT 1100 S Berlina	1,60	1950-1952	<1100	SC	0,15	0,10	0,35	0
597	MARINO (BRANDOLI)	FIAT 750 barchetta	1,45	1953-1957	<750	SC	0,10	0	0,35	0
598	MARINO (BRANDOLI)	FIAT 750 berlina	1,45	1953-1957	<750	SC	0,10	0	0,35	0
599	MARINO (BRANDOLI)	FIAT 750 S berlina	1,50	1950-1952	<750	SC	0,15	0	0,35	0
600	MARZOTTO-FERRARI	212 Export berlina Reggiani - Fontana "Uovo"	1,65	1950-1952	>1101	SC	0,15	0,15	0,35	0
601	MARZOTTO-FERRARI	212 Export spider Reggiani - Fontana	1,65	1950-1952	>1101	SC	0,15	0,15	0,35	0
602	MARZOTTO-FERRARI	340 America spider Fontana	1,65	1950-1952	>1101	SC	0,15	0,15	0,35	0
603	MASERATI	Tipo 26 B MM	1,75	1927-1929	>1101	SS	0,35	0,15	0,25	0
604	MASERATI	Tipo 26 MM spider	1,75	1927-1929	>1101	SS	0,35	0,15	0,25	0
605	MASERATI	Tipo 26 M Sport	1,70	1930-1934	>1101	SS	0,30	0,15	0,25	0
606	MASERATI	Tipo 26 C 1100	1,70	1930-1934	<1100	SS	0,30	0,10	0,25	0,05
607	MASERATI	Tipo 26 C 1500	1,70	1930-1934	>1101	SS	0,30	0,15	0,25	0
608	MASERATI	4 CTR 1100	1,70	1930-1934	<1100	SS	0,30	0,10	0,25	0,05

	MARCA MARQUE	MODELLO MODEL	COEFF. Multiplier	CALCULATION FACTOR						WINNER FACTOR
				PERIOD	CLASS	CAT.	PERIOD	CLASS	CAT.	
609	MASERATI	4CS 1100	1,70	1930-1934	<1100	SS	0,30	0,10	0,25	0,05
610	MASERATI	4 CS 1500 Campari & Sorniotti	1,70	1930-1934	>1101	SS	0,30	0,15	0,25	0
611	MASERATI	4 CS 1500	1,70	1935-1940	>1101	SS	0,25	0,15	0,25	0,05
612	MASERATI	6C/34	1,75	1935-1940	>1101	SC	0,25	0,15	0,35	0
613	MASERATI	Tipo 8C 26B 2000 Menarini	1,65	1935-1940	>1101	SS	0,25	0,15	0,25	0
614	MASERATI	Tipo 26 spider Menarini	1,65	1935-1940	>1101	SS	0,25	0,15	0,25	0
615	MASERATI	A6 GCS berlina	1,70	1947-1949	>1101	SC	0,20	0,15	0,35	0
616	MASERATI	A6 GCS spider	1,70	1947-1949	>1101	SC	0,20	0,15	0,35	0
617	MASERATI	A6 1500 berlina Pinin Farina	1,55	1947-1949	>1101	S	0,20	0,15	0,20	0
618	MASERATI	A6 1500 berlina	1,45	1950-1952	>1101	SP	0,15	0,15	0,15	0
619	MASERATI	A6 GCS/53 Fantuzzi	1,65	1953-1957	>1101	SC	0,10	0,15	0,35	0,05
620	MASERATI	A6 GCS /53 spider Vignale	1,60	1953-1957	>1101	SC	0,10	0,15	0,35	0
621	MASERATI	A6 GCS 2500	1,60	1953-1957	>1101	SC	0,10	0,15	0,35	0
622	MASERATI	A6 G 54 Zagato	1,45	1953-1957	>1101	S	0,10	0,15	0,20	0
623	MASERATI	150 S	1,60	1953-1957	>1101	SC	0,10	0,15	0,35	0
624	MASERATI	200 SI	1,60	1953-1957	>1101	SC	0,10	0,15	0,35	0
625	MASERATI	300 S spider Fantuzzi	1,60	1953-1957	>1101	SC	0,10	0,15	0,35	0
626	MASERATI	350 S spider Fantuzzi	1,60	1953-1957	>1101	SC	0,10	0,15	0,35	0
627	MASERATI	450 S spider Fantuzzi	1,60	1953-1957	>1101	SC	0,10	0,15	0,35	0
628	MASETTI	FIAT 500 siluro Marmini	1,55	1947-1949	<750	SC	0,20	0	0,35	0
629	MERCEDES-BENZ	710 SS *	1,65	1930-1934	>1101	S	0,30	0,15	0,20	0
630	MERCEDES-BENZ	710 SSK	1,75	1930-1934	>1101	SS	0,30	0,15	0,25	0,05
631	MERCEDES-BENZ	720 SSKL (winner 1931)	1,80	1930-1934	>1101	SS	0,30	0,15	0,25	WOA
632	MERCEDES-BENZ	300 SL Prototipo	1,65	1950-1952	>1101	SC	0,15	0,15	0,35	0
633	MERCEDES-BENZ	300 SLR (winner 1955)	1,80	1953-1957	>1101	SC	0,10	0,15	0,35	WOA
634	MERCEDES-BENZ	180 D	1,30	1953-1957	>1101	T	0,10	0,15	0	0,05
635	MERCEDES-BENZ	220	1,25	1953-1957	>1101	T	0,10	0,15	0	0
636	MERCEDES-BENZ	220 A	1,30	1953-1957	>1101	T	0,10	0,15	0	0,05
637	MERCEDES-BENZ	300 SL (W198)	1,40	1953-1957	>1101	GT	0,10	0,15	0,10	0,05
638	MERCEDES-BENZ	SC 180 Coupé	1,35	1953-1957	>1101	GT	0,10	0,15	0,10	0
639	MERCEDES-BENZ	190 SL	1,35	1953-1957	>1101	GT	0,10	0,15	0,10	0
640	MG	K-3 Magnette	1,70	1930-1934	<1100	SS	0,30	0,10	0,25	0,05
641	MG	C-Type "Midget" compressore	1,55	1930-1934	<750	SS	0,30	0	0,25	0
642	MG	SA berlina	1,55	1935-1940	>1101	SP	0,25	0,15	0,15	0
643	MG	Q-Type *	1,45	1935-1940	<750	S	0,25	0	0,20	0
644	MG	PB	1,55	1935-1940	>1101	SP	0,25	0,15	0,15	0
645	MG	TB *	1,60	1935-1940	>1101	S	0,25	0,15	0,20	0
646	MG	TF (1250 cc) *	1,35	1953-1957	>1101	GT	0,10	0,15	0,10	0
647	MG	Magnette berlina	1,25	1953-1957	>1101	T	0,10	0,15	0	0
648	MG	MG A	1,35	1953-1957	>1101	GT	0,10	0,15	0,10	0
649	MG	MG A "WORKS"	1,40	1953-1957	>1101	SP	0,10	0,15	0,15	0
650	MILAN (RUGGERI)	S.I.A.T.A. 1100 berlina Viotti	1,55	1935-1940	<1100	S	0,25	0,10	0,20	0
651	MOR & SCA	FIAT 500 Sport	1,45	1947-1949	<750	SC	0,10	0	0,35	0
652	MORETTI	600 MM	1,35	1950-1952	<750	S	0,15	0	0,20	0
653	MORETTI	750 berlina	1,10	1953-1957	<750	T	0,10	0	0	0
654	MORETTI	750 berlina Zagato	1,30	1953-1957	<750	S	0,10	0	0,20	0
655	MORETTI	750 coupé	1,20	1953-1957	<750	GT	0,10	0	0,10	0
656	MORETTI	750 Gran Sport berlina	1,30	1953-1957	<750	S	0,10	0	0,20	0

	MARCA MARQUE	MODELLO MODEL	COEFF. Multiplier	CALCULATION FACTOR						WINNER FACTOR
				PERIOD	CLASS	CAT.	PERIOD	CLASS	CAT.	
657	MORETTI	750 S	1,50	1950-1952	<750	SC	0,15	0	0,35	0
658	MORETTI	750 S berlina	1,30	1953-1957	<750	S	0,10	0	0,20	0
659	MORETTI	750 S berlinetta	1,45	1953-1957	<750	SC	0,10	0	0,35	0
660	MORETTI	750 S spider	1,45	1953-1957	<750	SC	0,10	0	0,35	0
661	MORETTINI-FLORIDA	FIAT 508 spider Sport Internazionale	1,60	1935-1940	<1100	SS	0,25	0,10	0,25	0
662	MOTOR RG (REMO GATTAI)	FIAT RG 1750 S		1947-1949	<750	SC	0,20	0	0,35	0
663	MOTOR RG (REMO GATTAI)	FIAT-LANCIA RG 11100 S	1,65	1947-1949	<1100	SC	0,20	0,10	0,35	0
664	NARDI-DANESE	750 B.M.W. Motto	1,55	1947-1949	<750	SC	0,20	0	0,35	0
665	NARDI-DANESE	Alfa Romeo 6C 2500 SS spider S.A.I.L.	1,55	1947-1949	>1101	S	0,20	0,15	0,20	0
666	NARDI-DANESE	Alfa Romeo 6C 2500 SS siluro "Revelli"	1,70	1947-1949	>1101	SC	0,20	0,15	0,35	0
667	NARDI-DANESE	Alfa Romeo 6C 2500 SS coupè "Revelli"	1,70	1947-1949	>1101	SC	0,20	0,15	0,35	0
668	NARDI-DANESE	B.M.W. 750 siluro	1,35	1950-1952	<750	S	0,15	0	0,20	0
669	NARDI-DANESE	1100 S FIAT berlinetta	1,45	1950-1952	<1100	S	0,15	0,10	0,20	0
670	NARDI-DANESE	815 Auto Avio 1500 spider	1,65	1950-1952	>1101	SC	0,15	0,15	0,35	0
671	NARDI-DANESE	750	1,50	1950-1952	<750	SC	0,15	0	0,35	0
672	NARDI-DANESE	"Marco" spider Morelli	1,60	1953-1957	>1101	SC	0,10	0,15	0,35	0
673	NARDI-DANESE	2000 S	1,60	1953-1957	>1101	SC	0,10	0,15	0,35	0
674	NARDI-DANESE	750 S	1,45	1953-1957	<750	SC	0,10	0	0,35	0
675	NARDI-DUBOIS	Peugeot berlinetta Frua	1,45	1953-1957	>1101	S	0,10	0,15	0,20	0
676	NASH-HEALEY	Coupè 4143 cm3	1,50	1950-1952	>1101	S	0,20	0,15	0,15	0
677	NASH-HEALEY	Sports 4138 cm3	1,45	1950-1952	>1101	SP	0,15	0,15	0,15	0
678	NASH-HEALEY	Sport (barchetta) 4143 cm3	1,50	1950-1952	>1101	S	0,20	0,15	0,15	0
679	NSU-FIAT	750 sport	1,40	1947-1949	<750	S	0,20	0	0,20	0
680	O.M.	469	1,70	1927-1929	>1101	S	0,35	0,15	0,20	0
681	O.M.	665 S Superba 2000 cm3 (winner 1927)	1,80	1927-1929	>1101	SS	0,35	0,15	0,25	WOA
682	O.M.	665 S MM Superba 2000 cm3	1,80	1927-1929	>1101	SS	0,35	0,15	0,25	0,05
683	O.M.	665 S MM Superba 2200 cm3	1,80	1927-1929	>1101	SS	0,35	0,15	0,25	0,05
684	O.M.	665 SS MM Superba 2200 cm3	1,80	1927-1929	>1101	SS	0,35	0,15	0,25	0,05
685	O.M.	665 N 2000 cm3	1,50	1927-1929	>1101	T	0,35	0,15	0	0
686	O.R.C.A.	1100 spider	1,50	1947-1949	<1100	S	0,20	0,10	0,20	0
687	O.S.C.A.	MT4 1350	1,70	1947-1949	>1101	SC	0,20	0,15	0,35	0
688	O.S.C.A.	MT4 1100	1,65	1950-1952	<1100	SC	0,15	0,10	0,35	0,05
689	O.S.C.A.	MT4 1100 siluro	1,60	1950-1952	<1100	SC	0,15	0,10	0,35	0
690	O.S.C.A.	MT4 1350 berlinetta Frua	1,65	1950-1952	>1101	SC	0,15	0,15	0,35	0
691	O.S.C.A.	MT4 1100 2AD	1,65	1950-1952	<1100	SC	0,15	0,10	0,35	0,05
692	O.S.C.A.	MT4 1100 2AD hardtop	1,60	1950-1952	<1100	SC	0,15	0,10	0,35	0
693	O.S.C.A.	MT4 1100 2AD berlinetta Vignale	1,55	1953-1957	<1100	SC	0,10	0,10	0,35	0
694	O.S.C.A.	MT4 1500 2AD	1,65	1953-1957	>1101	SC	0,10	0,15	0,35	0,05
695	O.S.C.A.	2000 S	1,60	1953-1957	>1101	SC	0,10	0,15	0,35	0
696	O.S.C.A.	S 187 - 750	1,50	1953-1957	<750	SC	0,10	0	0,35	0,05
697	O.S.C.A.	S 950	1,60	1953-1957	<1100	SC	0,10	0,10	0,35	0,05
698	O.S.C.A.	S 1500	1,60	1953-1957	>1101	SC	0,10	0,15	0,35	0
699	O.S.C.A.	TN 1500	1,60	1953-1957	>1101	SC	0,10	0,15	0,35	0
700	O.S.F.A.	FIAT - Lancia 750 spider	1,55	1947-1949	<750	SC	0,20	0	0,35	0
701	O.S.F.A.	FIAT - Lancia Ardea 750 barchetta	1,55	1947-1949	<750	SC	0,20	0	0,35	0
702	O.S.F.A.	FIAT 750 barchetta	1,50	1950-1952	<750	SC	0,15	0	0,35	0
703	O.S.F.A.	Lancia 750 barchetta	1,45	1953-1957	<750	SC	0,10	0	0,35	0

	MARCA MARQUE	MODELLO MODEL	COEFF. Multiplier	CALCULATION FACTOR						WINNER FACTOR
				PERIOD	CLASS	CAT.	PERIOD	CLASS	CAT.	
704	O.S.F.A.	Gilco Ardea 750 Spider	1,45	1953-1957	<750	SC	0,10	0	0,35	0
705	OLDSMOBILE	88 5300 cc	1,25	1953-1957	>1101	T	0,10	0,15	0	0
706	ORLANDO	FIAT 1100 siluro	1,45	1950-1952	<1100	S	0,15	0,10	0,20	0
707	ORTOLANI	Faccioli FIAT 1100 siluro	1,45	1950-1952	<1100	S	0,15	0,10	0,20	0
708	OVERLAND	3000	1,65	1930-1934	>1101	S	0,30	0,15	0,20	0
709	P.F.L.	Aprilia berlinetta Viotti	1,35	1947-1949	>1101	T	0,20	0,15	0	0
710	PAGANELLI-LANCIA	Aurelia B 20 2000 sport	1,60	1953-1957	>1101	SC	0,10	0,15	0,35	0
711	PANHARD ET LEVASSOR	Dyna	1,20	1950-1952	<750	T	0,15	0	0	0,05
712	PANHARD ET LEVASSOR	Dyna	1,10	1953-1957	<750	T	0,10	0	0	0
713	PANHARD ET LEVASSOR	Dyna X86 berlinetta Allemano	1,35	1953-1957	<750	S	0,10	0	0,20	0,05
714	PANHARD ET LEVASSOR	Dyna X86	1,15	1950-1952	<750	T	0,15	0	0	0
715	PANHARD ET LEVASSOR	Dyna X86 berlinetta	1,25	1950-1952	<750	GT	0,15	0	0,10	0
716	PANHARD ET LEVASSOR	Dyna berlinetta	1,20	1953-1957	<750	GT	0,10	0	0,10	0
717	PANHARD ET LEVASSOR	Dyna 130 S	1,20	1953-1957	<1100	T	0,10	0,10	0	0
718	PANHARD ET LEVASSOR	Dyna X87	1,10	1953-1957	<750	T	0,10	0	0	0
719	PANHARD ET LEVASSOR	Dyna spider	1,20	1953-1957	<750	GT	0,10	0	0,10	0
720	PANHARD ET LEVASSOR	Dyna tipo 54	1,10	1953-1957	<750	T	0,10	0	0	0
721	PANHARD ET LEVASSOR	Dyna Z	1,20	1953-1957	<1100	T	0,10	0,10	0	0
722	PANHARD ET LEVASSOR	Monopole berlinetta aerodinamica	1,30	1953-1957	<750	S	0,10	0	0,20	0
723	PARIANI	OSCA MT4 1350	1,55	1947-1949	<750	SC	0,20	0	0,35	0
724	PARISOTTO	750 Pasqualin barchetta	1,50	1950-1952	<750	SC	0,15	0	0,35	0
725	PARISOTTO	Giannini 750 S	1,45	1953-1957	<750	SC	0,10	0	0,35	0
726	PASQUALIN	FIAT 750 spider	1,55	1947-1949	<750	SC	0,20	0	0,35	0
727	PASQUALIN	Giannini - FIAT spider	1,50	1950-1952	<750	SC	0,15	0	0,35	0
728	PASQUALIN	GIANNINI FIAT 750 S	1,55	1950-1952	<750	SC	0,15	0	0,35	0,05
729	PASQUALIN	FIAT 750 S	1,50	1950-1952	<750	SC	0,15	0	0,35	0
730	PASQUALIN	Giannini 750 spider	1,45	1953-1957	<750	SC	0,10	0	0,35	0
731	PATRIARCA	FIAT 750 spider	1,55	1947-1949	<750	SC	0,20	0	0,35	0
732	PATRIARCA	FIAT 750 S	1,50	1950-1952	<750	SC	0,15	0	0,35	0
733	PATRIARCA	FIAT 1100 Sport	1,60	1950-1952	<1100	SC	0,15	0,10	0,35	0
734	PATRIARCA	Giannini berlinetta Faina	1,55	1950-1952	<750	SC	0,15	0	0,35	0,05
735	PATRIARCA	Giannini siluro Faina	1,50	1950-1952	<750	SC	0,15	0	0,35	0
736	PATRIARCA	Giannini 750 berlinetta Zagato	1,45	1953-1957	<750	SC	0,10	0	0,35	0
737	PATRIARCA	Giannini 750 barchetta	1,45	1953-1957	<750	SC	0,10	0	0,35	0
738	PEUGEOT	5 HP spider tipo MM	1,70	1927-1929	<750	S	0,35	0,10	0,20	0,05
739	PEUGEOT	5 HP tipo MM	1,65	1927-1929	<1100	S	0,35	0,10	0,20	0
740	PEUGEOT	203	1,40	1950-1952	>1101	GT	0,15	0,15	0,10	0
741	PEUGEOT	203	1,30	1953-1957	>1101	T	0,10	0,15	0	0,05
742	PEUGEOT	203 Speciale	1,45	1953-1957	>1101	S	0,10	0,15	0,20	0
743	PEUGEOT	203 coupé	1,35	1953-1957	>1101	GT	0,10	0,15	0,10	0
744	PEUGEOT	403 1300	1,25	1953-1957	>1101	T	0,10	0,15	0	0
745	PEUGEOT	403 1500	1,30	1953-1957	>1101	T	0,10	0,15	0	0,05
746	PICON	Panhard 750 Sport	1,45	1953-1957	<750	SC	0,10	0	0,35	0
747	PLATÉ	Alfa Romeo 6C 2300 siluro Zagato	1,75	1935-1940	>1101	SC	0,25	0,15	0,35	0
748	PORSCHE	356 1100	1,40	1950-1952	<1100	GT	0,15	0,10	0,10	0,05
749	PORSCHE	356 1290	1,35	1953-1957	>1101	GT	0,10	0,15	0,10	0
750	PORSCHE	356 1290 Super	1,40	1953-1957	>1101	GT	0,10	0,15	0,10	0,05
751	PORSCHE	356 A 1290	1,35	1953-1957	>1101	GT	0,10	0,15	0,10	0

	MARCA MARQUE	MODELLO MODEL	COEFF. Multiplier	CALCULATION FACTOR						WINNER FACTOR
				PERIOD	CLASS	CAT.	PERIOD	CLASS	CAT.	
752	PORSCHE	356 1500 SL [carrozzeria alluminio]	1,40	1950-1952	>1101	GT	0,15	0,15	0,10	0
753	PORSCHE	356 1500	1,45	1950-1952	>1101	GT	0,15	0,15	0,10	0,05
754	PORSCHE	356 1500	1,35	1953-1957	>1101	GT	0,10	0,15	0,10	0
755	PORSCHE	356 1500 Super	1,40	1953-1957	>1101	GT	0,10	0,15	0,10	0,05
756	PORSCHE	356 A 1600	1,35	1953-1957	>1101	GT	0,10	0,15	0,10	0
757	PORSCHE	356 A 1600 Super	1,35	1953-1957	>1101	GT	0,10	0,15	0,10	0
758	PORSCHE	356 1500 GS Carrera	1,45	1953-1957	>1101	SP	0,10	0,15	0,15	0,05
759	PORSCHE	356 A 1500 GS Carrera	1,45	1953-1957	>1101	SP	0,10	0,15	0,15	0,05
760	PORSCHE	356 1500 Speedster	1,40	1953-1957	>1101	GT	0,10	0,15	0,10	0,05
761	PORSCHE	550 Spyder RS	1,65	1953-1957	>1101	SC	0,10	0,15	0,35	0,05
762	PORSCHE	550 Spyder A/1500 RS	1,65	1953-1957	>1101	SC	0,10	0,15	0,35	0,05
763	PULIDORI	FIAT 750	1,55	1947-1949	<750	SC	0,20	0	0,35	0
764	PULIDORI	FIAT 750 spider	1,50	1950-1952	<750	SC	0,15	0	0,35	0
765	RALLY	ABC 1100 (modèles competition)	1,70	1927-1929	<1100	SS	0,35	0,10	0,25	0
766	RENAULT	4 CV	1,20	1950-1952	<750	T	0,15	0	0	0,05
767	RENAULT	4CV/1063	1,20	1950-1952	<750	T	0,15	0	0	0,05
768	RENAULT	4 CV berlinetta	1,20	1953-1957	<750	GT	0,10	0	0,10	0
769	RENAULT	4 CV coupé	1,20	1953-1957	<750	GT	0,10	0	0,10	0
770	RENAULT	4 CV coupé speciale	1,20	1953-1957	<750	GT	0,10	0	0,10	0
771	RENAULT	4 CV spider	1,30	1953-1957	<750	S	0,10	0	0,20	0
772	RENAULT	4CV/1063 berlinetta Allemano	1,25	1953-1957	<750	GT	0,10	0	0,10	0,05
773	RENAULT	750 berlinetta	1,25	1950-1952	<750	GT	0,15	0	0,10	0
774	RENAULT	750 S	1,30	1953-1957	<750	S	0,10	0	0,20	0
775	RENAULT	Dauphine	1,25	1953-1957	<1100	T	0,10	0,10	0	0,05
776	RICCI	B.M.W. 750 spider	1,55	1947-1949	<750	SC	0,20	0	0,35	0
777	RILEY	Sprite TT	1,60	1935-1940	>1101	S	0,25	0,15	0,20	0
778	RIVA-PAGANI	1100 FIAT barchetta	1,60	1950-1952	<1100	SC	0,15	0,10	0,35	0
779	ROCCA	1100	1,60	1930-1934	<1100	S	0,30	0,10	0,20	0
780	ROSELLI	1100 barchetta Colli	1,65	1947-1949	<1100	SC	0,20	0,10	0,35	0
781	ROSELLI	FIAT 1100 barchetta aerodinamica Colli	1,70	1935-1940	<1100	SC	0,25	0,10	0,35	0
782	ROVELLI	FIAT 1100 Testadoro spider Castagna	1,65	1947-1949	<1100	SC	0,20	0,10	0,35	0
783	ROVELLI	FIAT 1100 spider hard-top	1,65	1947-1949	<1100	SC	0,20	0,10	0,35	0
784	ROVER	75	1,25	1953-1957	>1101	T	0,10	0,15	0	0
785	S.I.A.T.A	FIAT 521 C	1,70	1927-1929	>1101	S	0,35	0,15	0,20	0
786	S.I.A.T.A	FIAT 514 S	1,60	1930-1934	>1101	SP	0,30	0,15	0,15	0
787	S.I.A.T.A.	FIAT 514 MM	1,65	1930-1934	>1101	S	0,30	0,15	0,20	0
788	S.I.A.T.A	FIAT 514 compressore	1,60	1930-1934	>1101	SP	0,30	0,15	0,15	0
789	S.I.A.T.A	FIAT 508 S berlinetta Ghia	1,55	1930-1934	<1100	SP	0,30	0,10	0,15	0
790	S.I.A.T.A	FIAT 508 S	1,55	1930-1934	<1100	SP	0,30	0,10	0,15	0
791	S.I.A.T.A	FIAT 508 S compressore berlinetta Ghia	1,50	1935-1940	<1100	SP	0,25	0,10	0,15	0
792	S.I.A.T.A	"Gran Sport" spider 636 cm3	1,50	1935-1940	<750	S	0,25	0	0,20	0,05
793	S.I.A.T.A	FIAT 508 CS berlinetta	1,35	1935-1940	<1100	T	0,25	0,10	0	0
794	S.I.A.T.A	FIAT 1500 Spider	1,45	1935-1940	>1101	T	0,25	0,15	0	0,05
795	S.I.A.T.A	FIAT 1100 MM berlinetta Viotti	1,55	1935-1940	<1100	S	0,25	0,10	0,20	0
796	S.I.A.T.A	FIAT 500 spider Zagato	1,45	1935-1940	<750	S	0,25	0	0,20	0
797	S.I.A.T.A	FIAT 1100 spider	1,60	1935-1940	<1100	SS	0,25	0,10	0,25	0
798	S.I.A.T.A	FIAT 500 spider	1,50	1935-1940	<750	SS	0,25	0	0,25	0
799	S.I.A.T.A	FIAT 500 Pescara	1,50	1935-1940	<750	SS	0,25	0	0,25	0

	MARCA MARQUE	MODELLO MODEL	COEFF. Multiplier	CALCULATION FACTOR						WINNER FACTOR
				PERIOD	CLASS	CAT.	PERIOD	CLASS	CAT.	
800	S.I.A.T.A	FIAT 750 spider	1,50	1935-1940	<750	SS	0,25	0	0,25	0
801	S.I.A.T.A	FIAT 750 spider Bertone	1,55	1947-1949	<750	SC	0,20	0	0,35	0
802	S.I.A.T.A	FIAT 750 sport	1,55	1947-1949	<750	SC	0,20	0	0,35	0
803	S.I.A.T.A	TC 500 sport	1,55	1947-1949	<750	SC	0,20	0	0,35	0
804	S.I.A.T.A	750 spider	1,30	1953-1957	<750	S	0,10	0	0,20	0
805	S.I.A.T.A	FIAT 750 barchetta	1,55	1947-1949	<750	SC	0,20	0	0,35	0
806	S.I.A.T.A	750 S	1,50	1950-1952	<750	SC	0,15	0	0,35	0
807	S.I.A.T.A	Daina Gran Sport Stabilimenti Farina	1,45	1950-1952	>1101	SP	0,15	0,15	0,15	0
808	S.I.A.T.A	Daina Sport Stabilimenti Farina Coupé	1,45	1950-1952	>1101	SP	0,15	0,15	0,15	0
809	S.I.A.T.A	Daina Sport Berlinetta Bertone	1,45	1950-1952	>1101	SP	0,15	0,15	0,15	0
810	S.I.A.T.A	SC 750 siluro	1,50	1950-1952	<750	SC	0,15	0	0,35	0
811	S.I.A.T.A	208 S berlinetta Pinin Farina	1,50	1950-1952	>1101	S	0,15	0,15	0,20	0
812	S.I.A.T.A	Amica	1,30	1953-1957	<750	S	0,10	0	0,20	0
813	S.I.A.T.A	300 BC berlinetta	1,25	1953-1957	<750	SP	0,10	0	0,15	0
814	S.I.A.T.A	1100 GT	1,35	1953-1957	<1100	SP	0,10	0,10	0,15	0
815	S.I.A.T.A	1100 TV Coupé Vignale	1,35	1953-1957	<1100	SP	0,10	0,10	0,15	0
816	S.I.A.T.A	Daina Sport Coupé 1250 Pinin Farina	1,45	1953-1957	>1101	S	0,10	0,15	0,20	0
817	S.I.A.T.A	1250 GT	1,45	1953-1957	>1101	S	0,10	0,15	0,20	0
818	S.I.A.T.A	1250 GT Zagato	1,35	1953-1957	>1101	GT	0,10	0,15	0,10	0
819	S.I.A.T.A	300 BC convertibile hardtop	1,30	1953-1957	<750	S	0,10	0	0,20	0
820	S.I.A.T.A	FIAT 750 berlinetta	1,30	1953-1957	<750	S	0,10	0	0,20	0
821	SAAB	93	1,15	1953-1957	<750	T	0,10	0	0	0,05
822	SAIL	FIAT barchetta 1100	1,65	1947-1949	<1100	SC	0,20	0,10	0,35	0
823	SALMSON	AL 1100 bialbero siluro corsa	1,65	1927-1929	<1100	S	0,35	0,10	0,20	0
824	SALMSON	AL 1100 siluro corsa	1,70	1927-1929	<1100	SS	0,35	0,10	0,25	0
825	SALMSON	AL 1100 spider corsa	1,70	1927-1929	<1100	SS	0,35	0,10	0,25	0
826	SALMSON	AL 1100	1,65	1927-1929	<1100	S	0,35	0,10	0,20	0
827	SALMSON	1100	1,65	1927-1929	<1100	S	0,35	0,10	0,20	0
828	SALMSON	2300	1,35	1953-1957	>1101	GT	0,10	0,15	0,10	0
829	SALMSON	2300 Sport	1,35	1953-1957	>1101	GT	0,10	0,15	0,10	0
830	SAM	C25 F spider	1,65	1927-1929	<1100	S	0,35	0,10	0,20	0
831	SAM	C25 J spider	1,65	1927-1929	<1100	S	0,35	0,10	0,20	0
832	SCAT CEIRANO	S 150 VVV	1,65	1930-1934	>1101	S	0,30	0,15	0,20	0
833	SCUDERIA ITALFRANCE	Panhard Dyna X86 berlinetta Allemano	1,30	1950-1952	<750	SP	0,15	0	0,15	0
834	SCUDERIA ITALFRANCE	Panhard Dyna berlinetta Colli "disco volante"	1,45	1953-1957	<750	SC	0,10	0	0,35	0
835	SCUDERIA ITALFRANCE	Panhard Dyna X 86 Berlinetta Colli	1,30	1953-1957	<750	S	0,10	0	0,20	0
836	SCUDERIA ITALFRANCE	Panhard Dyna X 86 Berlinetta Zagato	1,30	1953-1957	<750	S	0,10	0	0,20	0
837	SCUDERIA ITALFRANCE	Panhard Dyna X 86 Spider Allemano	1,30	1953-1957	<750	S	0,10	0	0,20	0
838	SIGHINOLFI	Ermini 1100 siluro	1,60	1950-1952	<1100	SC	0,15	0,10	0,35	0
839	SIGHINOLFI	FIAT 1100 S	1,55	1953-1957	<1100	SC	0,10	0,10	0,35	0
840	SIGHINOLFI	FIAT 1100 siluro Campana	1,65	1947-1949	<1100	SC	0,20	0,10	0,35	0
841	SIMCA	Aronde	1,30	1950-1952	>1101	T	0,15	0,15	0	0
842	SIMCA	Aronde S	1,25	1953-1957	>1101	T	0,10	0,15	0	0
843	SIMCA-GORDINI	1100 Sport *	1,40	1947-1949	<750	S	0,20	0	0,20	0
844	STAL	750 GT *	1,35	1950-1952	<750	S	0,15	0	0,20	0
845	STANGA	FIAT 500A testa S.I.A.T.A. barchetta Cervi & Corna	1,55	1947-1949	<750	SC	0,20	0	0,35	0
846	STANGA	FIAT 750 S	1,45	1953-1957	<750	SC	0,10	0	0,35	0
847	STANGA	Giannini 750 barchetta Motto	1,50	1950-1952	<750	SC	0,15	0	0,35	0

	MARCA MARQUE	MODELLO MODEL	COEFF. Multiplier	CALCULATION FACTOR						WINNER FACTOR
				PERIOD	CLASS	CAT.	PERIOD	CLASS	CAT.	
848	STANGA	Giannini 750 berlinetta Motto	1,45	1953-1957	<750	SC	0,10	0	0,35	0
849	STANGA	Giannini 750 siluro Motto	1,50	1950-1952	<750	SC	0,15	0	0,35	0
850	STANGUELLINI	500 Spider spider Torricelli	1,55	1935-1940	<750	SS	0,25	0	0,25	0,05
851	STANGUELLINI	FIAT 1100 spider Touring	1,60	1935-1940	<1100	SS	0,25	0,10	0,25	0
852	STANGUELLINI	1100 Hard Top	1,65	1935-1940	<1100	SS	0,25	0,10	0,25	0,05
853	STANGUELLINI	FIAT 1100 hardtop Carrozzeria Torricelli	1,60	1935-1940	<1100	SS	0,25	0,10	0,25	0
854	STANGUELLINI	FIAT 1100 spider Torricelli	1,60	1935-1940	<1100	SS	0,25	0,10	0,25	0
855	STANGUELLINI	FIAT 500 testa S.I.A.T.A. spider Torricelli	1,50	1935-1940	<750	SS	0,25	0	0,25	0
856	STANGUELLINI	1100 spider	1,65	1947-1949	<1100	SC	0,20	0,10	0,35	0
857	STANGUELLINI	1100 berlinetta Bertone	1,40	1947-1949	<1100	GT	0,20	0,10	0,10	0
858	STANGUELLINI	1100 spider Ala d'Oro	1,65	1947-1949	<1100	SC	0,20	0,10	0,35	0
859	STANGUELLINI	1100 hard-top Ala d'Oro	1,65	1947-1949	<1100	SC	0,20	0,10	0,35	0
860	STANGUELLINI	1100 Sport	1,65	1947-1949	<1100	SC	0,20	0,10	0,35	0
861	STANGUELLINI	2800 spider	1,70	1947-1949	>1101	SC	0,20	0,15	0,35	0
862	STANGUELLINI	750 S	1,55	1947-1949	<750	SC	0,20	0	0,35	0
863	STANGUELLINI	1100 hardtop	1,60	1950-1952	<1100	SC	0,15	0,10	0,35	0
864	STANGUELLINI	750 spider Campana	1,45	1953-1957	<750	SC	0,10	0	0,35	0
865	STANGUELLINI	1100 Sport	1,55	1953-1957	<1100	SC	0,10	0,10	0,35	0
866	STUDEBAKER	modello non identificato	1,45	1953-1957	>1101	S	0,10	0,15	0,20	0
867	SUNBEAM	Rapier	1,30	1953-1957	>1101	T	0,10	0,15	0	0,05
868	SUPERBA	FIAT 750 S	1,45	1953-1957	<750	SC	0,10	0	0,35	0
869	SVA	Giannini 750 Sport	1,50	1950-1952	<750	SC	0,15	0	0,35	0
870	TALBOT [GB]	AV 105 S	1,65	1930-1934	>1101	S	0,30	0,15	0,20	0
871	TALBOT-LAGO [F]	T 150C	1,65	1935-1940	>1101	SS	0,25	0,15	0,25	0
872	TALBOT-LAGO [F]	T26 GS	1,65	1950-1952	>1101	SC	0,15	0,15	0,35	0
873	TESTADORO-BRANCA	FIAT 750	1,50	1950-1952	<750	SC	0,15	0	0,35	0
874	TINARELLI	Lancia Aprilia barchetta	1,65	1935-1940	>1101	SS	0,25	0,15	0,25	0
875	TINARELLI	Ermini 1100 siluro	1,60	1950-1952	<1100	SC	0,15	0,10	0,35	0
876	TRIUMPH	TR2 Sports	1,45	1953-1957	>1101	SP	0,10	0,15	0,15	0,05
877	TRIUMPH	TR 3 Sports	1,35	1953-1957	>1101	GT	0,10	0,15	0,10	0
878	TRIUMPH	TR 3 Sports Works	1,40	1953-1957	>1101	SP	0,10	0,15	0,15	0
879	TUROLLA	FIAT 1100	1,65	1947-1949	<1100	SC	0,20	0,10	0,35	0
880	TUROLLA	FIAT 1100 S	1,65	1947-1949	<1100	SC	0,20	0,15	0,35	0
881	TUROLLA	FIAT 1500 spider	1,70	1947-1949	>1101	SC	0,20	0,15	0,35	0
882	TUROLLA	FIAT 500 A testa S.I.A.T.A.	1,55	1947-1949	<750	SC	0,20	0	0,35	0
883	TUROLLA	FIAT 500 A testa S.I.A.T.A. coupé Morelli	1,55	1947-1949	<750	SC	0,20	0	0,35	0
884	TUROLLA	FIAT 750 barchetta	1,50	1950-1952	<750	SC	0,15	0	0,35	0
885	TUROLLA	FIAT 750 berlinetta Morelli	1,50	1950-1952	<750	SC	0,15	0	0,35	0
886	TUROLLA	FIAT 750 Sport	1,55	1947-1949	<750	SC	0,20	0	0,35	0
887	URANIA	750 S	1,50	1950-1952	<750	SC	0,15	0	0,35	0
888	URANIA	B.M.W. 750 siluro	1,55	1947-1949	<750	SC	0,20	0	0,35	0
889	VERITAS	Comet RS *	1,60	1953-1957	>1101	SC	0,10	0,15	0,35	0
890	VERITAS	Panhard Dyna Gran Sport spider	1,50	1950-1952	<750	SC	0,15	0	0,35	0
891	VIBERTI	Aprilia berlinetta aerodinamica "Casa"	1,65	1935-1940	>1101	SS	0,25	0,15	0,25	0
892	VOISIN	C 14 3000 cm3	1,70	1927-1929	>1101	S	0,35	0,15	0,20	0
893	VOLKSWAGEN	"Maggiolino" motore Porsche 1.290 cm3	1,40	1953-1957	>1101	SP	0,10	0,15	0,15	0
894	VOLKSWAGEN	1100 "Maggiolino"	1,25	1950-1952	<1100	T	0,15	0,10	0	0
895	VOLKSWAGEN	1200 "Maggiolino"	1,25	1953-1957	>1101	T	0,10	0,15	0	0

	MARCA MARQUE	MODELLO MODEL	COEFF. Multiplier	CALCULATION FACTOR						WINNER FACTOR
				PERIOD	CLASS	CAT.	PERIOD	CLASS	CAT.	
896	VOLPINI	B.M.W. 328 barchetta	1,70	1947-1949	>1101	SC	0,20	0,15	0,35	0
897	VOLPINI	FIAT 1100 berlina Frua	1,40	1953-1957	<1100	S	0,10	0,10	0,20	0
898	VOLPINI	Lancia Aprilia	1,45	1947-1949	>1101	GT	0,20	0,15	0,10	0
899	VOLPINI	Lancia Aprilia	1,40	1950-1952	>1101	T	0,15	0,15	0,10	0
900	ZAGATO	FIAT 1500 spider	1,60	1935-1940	>1101	S	0,25	0,15	0,20	0
901	ZAGATO	FIAT 500 testa S.I.A.T.A. spider	1,60	1935-1940	>1101	S	0,25	0,15	0,20	0
902	ZAGATO	Lancia Aprilia spider	1,60	1935-1940	>1101	S	0,25	0,15	0,20	0
903	ZAGATO	FIAT 500 berlina panoramica	1,35	1950-1952	<750	S	0,15	0	0,20	0
904	ZAGATO	FIAT 750 MM berlina	1,30	1950-1952	<750	GT	0,15	0	0,10	0,05
905	ZAGATO	FIAT 1100 E berlina	1,40	1950-1952	>1101	GT	0,15	0,15	0,10	0
906	ZAGATO	FIAT 750 berlina	1,25	1950-1952	<750	GT	0,15	0	0,10	0
907	ZAGATO	FIAT 8V spider	1,45	1953-1957	>1101	S	0,10	0,15	0,20	0
908	ZAGATO	FIAT 8V berlina	1,50	1953-1957	>1101	S	0,10	0,15	0,20	0,05
909	ZAGATO	FIAT 750	1,30	1953-1957	<750	S	0,10	0	0,20	0
910	ZAGATO	FIAT 1100 GT	1,35	1953-1957	>1101	GT	0,10	0,15	0,10	0
911	ZAGATO	FIAT 1100 berlina	1,40	1953-1957	<1100	SP	0,10	0,10	0,15	0,05
912	ZAGATO	FIAT 1100/103 TV	1,30	1953-1957	<1100	GT	0,10	0,10	0,10	0
913	ZAGATO	FIAT 1100	1,40	1953-1957	<1100	S	0,10	0,10	0,20	0
914	ZAGATO	FIAT 600 berlina	1,20	1953-1957	<750	GT	0,10	0	0,10	0
915	ZAGATO	FIAT 600 coupé	1,20	1953-1957	<750	GT	0,10	0	0,10	0
916	ZAGATO	Lancia Appia GTZ	1,35	1953-1957	<1100	GT	0,10	0,10	0,10	0,05
917	ZAGATO	FIAT 1100 coupé	1,30	1953-1957	<1100	GT	0,10	0,10	0,10	0
918	ZAGATO	SIATA 1400 Sport	1,45	1953-1957	>1101	S	0,10	0,15	0,20	0
919	ZANNINI	750 S FIAT	1,45	1953-1957	<750	SC	0,10	0	0,35	0
920	ZANUSSI	FIAT 750 Sport MM	1,55	1947-1949	<750	SC	0,20	0	0,35	0
921	ZANUSSI	FIAT Fontebasso 750 Sport	1,50	1950-1952	<750	SC	0,15	0	0,35	0

* VETTURE ISCRITTE ALLA CORSA MA CHE NON HANNO PRESO IL VIA.

* CARS ENTERED IN THE RACE BUT WHICH HAVE NOT STARTED.

Significato Sigle e Abbreviazioni / Overview of acronyms and abbreviations:

- AC (AUTO CARRIERS LTD)
- A.L.F. (AVALLE LANCIA FIORIO)
- ALCA (ANONIMA LOMBARDA CABOTAGGIO AEREO)
- AMP (ALFA MASERATI PRETI)
- B.M.W. (BAYERISCHE MOTOREN WERKE)
- B.N.C. (BOLLACK, NETTER E CIE)
- CARGEM (CARNEVALLI GERONIMO)
- CFM (CHINELLATO FRANCESCO MESTRE)
- CI-MA (CICOGNANI MARCELLO) D.B. (DEUTSCH BONNET)
- D.L. (DERIVATA LANCIA VICI)
- E.F.A.C. (SOCIÉTÉ ECURIE FRANÇAIS AUTOMOBILES COMPÉTITION)
- F.L. (FIAT LAUREATI)
- FIAT (FABBRICA ITALIANA AUTOMOBILI TORINO)
- GIAUR (GIANNINI - URANIA)
- GILCO (GILBERTO COLOMBO)
- GPG (GIANNI PIETRO GENOVA)
- GUIŦIN (GUIDOTTI TINARELLI)
- MARDAL (MARZOTTO UMBERTO - DAL MORO)
- MG (MORRIS GARAGE)
- O.M. (OFFICINE MECCANICHE)
- O.R.C.A. (OFFICINA RIPARAZIONI COSTRUZIONE AUTOVEICOLI)
- O.S.C.A. (OFFICINE SPECIALIZZATE COSTRUZIONE AUTOMOBILI)
- O.S.F.A. (OFFICINA SPECIALIZZATA FACCIOLI ALDO)
- P.F.L. (PEZZOLI FIAT LANCIA)
- S.I.A.T.A. (SOCIETÀ ITALIANA APPLICAZIONE TRASFORMAZIONI AUTOMOBILISTICHE)
- SAAB (SVENSKA AEROPLAN AKTIEBOLAGET)
- SAM (SOCIETÀ AUTOMOBILI MOTORI)
- SVA (SOCIETÀ VALDOSTANA)

Attachment 7: Points table for the TT (PC/TT)

1000 MIGLIA 2024
TABELLA DEI PUNTEGGI PER LE PROVE CRONOMETRATE

centesimi di secondo		centesimi di secondo		centesimi di secondo		centesimi di secondo	
penalità	punti	penalità	punti	penalità	punti	penalità	punti
0	420	42	158	84	116	126	74
1	395	43	157	85	115	127	73
2	370	44	156	86	114	128	72
3	350	45	155	87	113	129	71
4	330	46	154	88	112	130	70
5	310	47	153	89	111	131	69
6	291	48	152	90	110	132	68
7	272	49	151	91	109	133	67
8	254	50	150	92	108	134	66
9	236	51	149	93	107	135	65
10	226	52	148	94	106	136	64
11	217	53	147	95	105	137	63
12	212	54	146	96	104	138	62
13	207	55	145	97	103	139	61
14	203	56	144	98	102	140	60
15	200	57	143	99	101	141	59
16	198	58	142	100	100	142	58
17	196	59	141	101	99	143	57
18	194	60	140	102	98	144	56
19	192	61	139	103	97	145	55
20	190	62	138	104	96	146	54
21	188	63	137	105	95	147	53
22	186	64	136	106	94	148	52
23	184	65	135	107	93	149	51
24	182	66	134	108	92	150	50
25	180	67	133	109	91	151	49
26	178	68	132	110	90	152	48
27	176	69	131	111	89	153	47
28	174	70	130	112	88	154	46
29	172	71	129	113	87	155	45
30	170	72	128	114	86	156	44
31	169	73	127	115	85	157	43
32	168	74	126	116	84	158	42
33	167	75	125	117	83	159	41
34	166	76	124	118	82	160	40
35	165	77	123	119	81	161	39
36	164	78	122	120	80	162	38
37	163	79	121	121	79	163	37
38	162	80	120	122	78	164	36
39	161	81	119	123	77	165	35
40	160	82	118	124	76	166	34
41	159	83	117	125	75	167	33

TABELLA DEI PUNTEGGI PER LE PROVE CRONOMETRATE

centesimi di secondo		centesimi di secondo		centesimi di secondo		centesimi di secondo	
penalità	punti	penalità	punti	penalità	punti	penalità	punti
168	32	205	0	242	0	279	0
169	31	206	0	243	0	280	0
170	30	207	0	244	0	281	0
171	29	208	0	245	0	282	0
172	28	209	0	246	0	283	0
173	27	210	0	247	0	284	0
174	26	211	0	248	0	285	0
175	25	212	0	249	0	286	0
176	24	213	0	250	0	287	0
177	23	214	0	251	0	288	0
178	22	215	0	252	0	289	0
179	21	216	0	253	0	290	0
180	20	217	0	254	0	291	0
181	19	218	0	255	0	292	0
182	18	219	0	256	0	293	0
183	17	220	0	257	0	294	0
184	16	221	0	258	0	295	0
185	15	222	0	259	0	296	0
186	14	223	0	260	0	297	0
187	13	224	0	261	0	298	0
188	12	225	0	262	0	299	0
189	11	226	0	263	0	300	0
190	10	227	0	264	0		
191	9	228	0	265	0		
192	8	229	0	266	0		
193	7	230	0	267	0		
194	6	231	0	268	0		
195	5	232	0	269	0		
196	4	233	0	270	0		
197	3	234	0	271	0		
198	2	235	0	272	0		
199	1	236	0	273	0		
200	0	237	0	274	0		
201	0	238	0	275	0		
202	0	239	0	276	0		
203	0	240	0	277	0		
204	0	241	0	278	0		

NOTA: il coefficiente assegnato alla vettura deve essere moltiplicato per i punti

Attachment 8: Points table for the AT (PM/AT)

1000 MIGLIA 2024
TABELLA DEI PUNTEGGI PER LE PROVE DI MEDIA

al secondo			al secondo			al secondo			al secondo		
penalità	punti ANTICIPO	punti RITARDO	penalità	punti ANTICIPO	punti RITARDO	penalità	punti ANTICIPO	punti RITARDO	penalità	punti ANTICIPO	punti RITARDO
0	420	420	42	53	158	84	0	116	126	-108	74
1	395	395	43	52	157	85	0	115	127	-111	73
2	370	370	44	51	156	86	0	114	128	-114	72
3	350	350	45	50	155	87	0	113	129	-117	71
4	330	330	46	48	154	88	0	112	130	-120	70
5	310	310	47	46	153	89	0	111	131	-123	69
6	291	291	48	44	152	90	0	110	132	-126	68
7	272	272	49	42	151	91	-3	109	133	-129	67
8	254	254	50	40	150	92	-6	108	134	-132	66
9	236	236	51	38	149	93	-9	107	135	-135	65
10	226	226	52	36	148	94	-12	106	136	-138	64
11	200	217	53	34	147	95	-15	105	137	-141	63
12	185	212	54	32	146	96	-18	104	138	-144	62
13	170	207	55	30	145	97	-21	103	139	-147	61
14	155	203	56	28	144	98	-24	102	140	-150	60
15	140	200	57	26	143	99	-27	101	141	-153	59
16	135	198	58	24	142	100	-30	100	142	-156	58
17	130	196	59	22	141	101	-33	99	143	-159	57
18	125	194	60	20	140	102	-36	98	144	-162	56
19	120	192	61	18	139	103	-39	97	145	-165	55
20	115	190	62	16	138	104	-42	96	146	-168	54
21	110	188	63	14	137	105	-45	95	147	-171	53
22	105	186	64	12	136	106	-48	94	148	-174	52
23	100	184	65	10	135	107	-51	93	149	-177	51
24	95	182	66	8	134	108	-54	92	150	-180	50
25	90	180	67	6	133	109	-57	91	151	-183	49
26	85	178	68	4	132	110	-60	90	152	-186	48
27	80	176	69	2	131	111	-63	89	153	-189	47
28	75	174	70	0	130	112	-66	88	154	-192	46
29	70	172	71	0	129	113	-69	87	155	-195	45
30	65	170	72	0	128	114	-72	86	156	-198	44
31	64	169	73	0	127	115	-75	85	157	-201	43
32	63	168	74	0	126	116	-78	84	158	-204	42
33	62	167	75	0	125	117	-81	83	159	-207	41
34	61	166	76	0	124	118	-84	82	160	-210	40
35	60	165	77	0	123	119	-87	81	161	-213	39
36	59	164	78	0	122	120	-90	80	162	-216	38
37	58	163	79	0	121	121	-93	79	163	-219	37
38	57	162	80	0	120	122	-96	78	164	-222	36
39	56	161	81	0	119	123	-99	77	165	-225	35
40	55	160	82	0	118	124	-102	76	166	-228	34
41	54	159	83	0	117	125	-105	75	167	-231	33

TABELLA DEI PUNTEGGI PER LE PROVE DI MEDIA

al secondo			al secondo			al secondo			al secondo		
penalità	punti ANTICIPO	punti RITARDO	penalità	punti ANTICIPO	punti RITARDO	penalità	punti ANTICIPO	punti RITARDO	penalità	punti ANTICIPO	punti RITARDO
168	-234	32	205	-345	0	242	-456	0	279	-567	0
169	-237	31	206	-348	0	243	-459	0	280	-570	0
170	-240	30	207	-351	0	244	-462	0	281	-573	0
171	-243	29	208	-354	0	245	-465	0	282	-576	0
172	-246	28	209	-357	0	246	-468	0	283	-579	0
173	-249	27	210	-360	0	247	-471	0	284	-582	0
174	-252	26	211	-363	0	248	-474	0	285	-585	0
175	-255	25	212	-366	0	249	-477	0	286	-588	0
176	-258	24	213	-369	0	250	-480	0	287	-591	0
177	-261	23	214	-372	0	251	-483	0	288	-594	0
178	-264	22	215	-375	0	252	-486	0	289	-597	0
179	-267	21	216	-378	0	253	-489	0	290	-600	0
180	-270	20	217	-381	0	254	-492	0	291	-603	0
181	-273	19	218	-384	0	255	-495	0	292	-606	0
182	-276	18	219	-387	0	256	-498	0	293	-609	0
183	-279	17	220	-390	0	257	-501	0	294	-612	0
184	-282	16	221	-393	0	258	-504	0	295	-615	0
185	-285	15	222	-396	0	259	-507	0	296	-618	0
186	-288	14	223	-399	0	260	-510	0	297	-621	0
187	-291	13	224	-402	0	261	-513	0	298	-624	0
188	-294	12	225	-405	0	262	-516	0	299	-627	0
189	-297	11	226	-408	0	263	-519	0	300	-630	0
190	-300	10	227	-411	0	264	-522	0	>300	-12000	0
191	-303	9	228	-414	0	265	-525	0			
192	-306	8	229	-417	0	266	-528	0			
193	-309	7	230	-420	0	267	-531	0			
194	-312	6	231	-423	0	268	-534	0			
195	-315	5	232	-426	0	269	-537	0			
196	-318	4	233	-429	0	270	-540	0			
197	-321	3	234	-432	0	271	-543	0			
198	-324	2	235	-435	0	272	-546	0			
199	-327	1	236	-438	0	273	-549	0			
200	-330	0	237	-441	0	274	-552	0			
201	-333	0	238	-444	0	275	-555	0			
202	-336	0	239	-447	0	276	-558	0			
203	-339	0	240	-450	0	277	-561	0			
204	-342	0	241	-453	0	278	-564	0			

NOTA: il coefficiente assegnato alla vettura deve essere moltiplicato per i punti